

# Montage- und Betriebsanleitung

EN Installation and operating instructions  
 ES Instrucciones de montaje y servicio  
 CS Návod pro montáž a provoz  
 FR Notice de montage et de mise en service

NL Montage- en bedrijfsinstructies  
 PL Instrukcja montażu i obsługi  
 SV Monterings- och driftinstruktion  
 HU Szerelési és használati útmutató  
 FI Asennus- ja käyttöohje

EL Συναρμολόγηση και οδηγίες λειτουργίας  
 IT Istruzioni per il montaggio e l'uso  
 RO Montaj și instrucțiuni de funcționare  
 RU Инструкция по монтажу и вводу в эксплуатацию

**PRTRS0011**  
**7612982224836**  
 2030025088

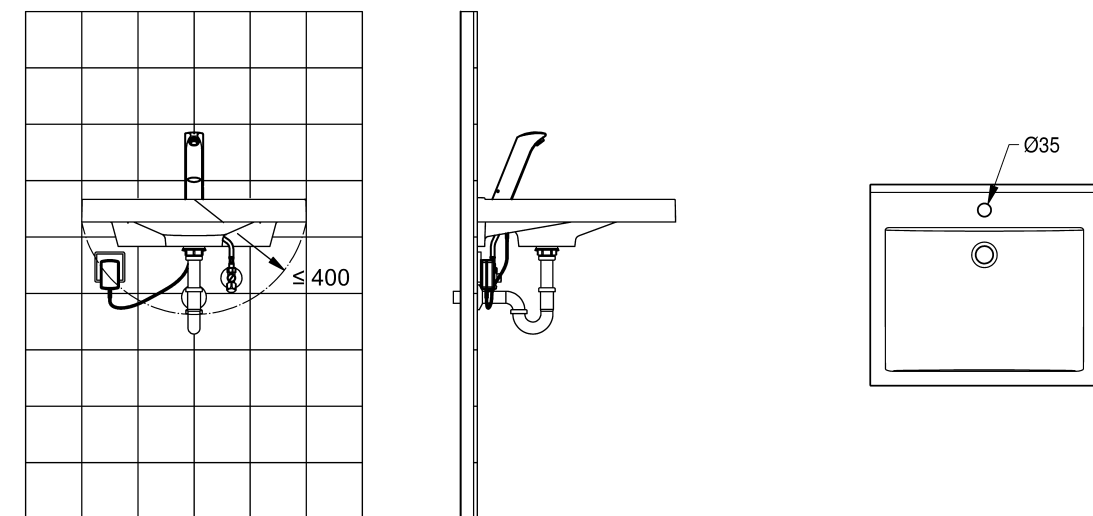
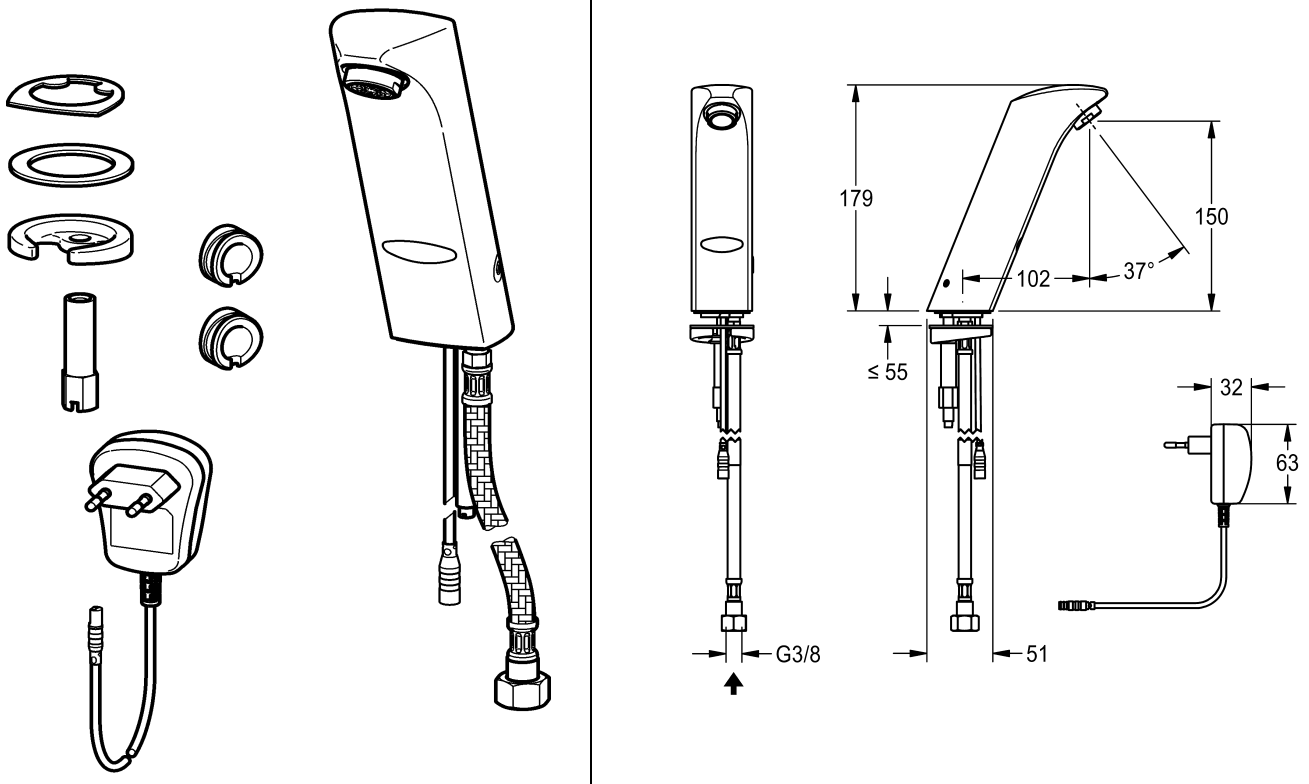

ZMI\_001\_2030025088-PRTRS0011\_#SALL\_#AQU\_#V1.fm / 20.05.15

- EN Important notes**  
Before installing flush piping system!  
After completing the installation, set the temperature limiter!  
The fitting must be operated only with original mesh filters and return flow inhibitors!
- FR Remarques importantes**  
Rincer les conduites avant d'installer !  
Une fois le montage terminé, régler la limitation de température !  
Ne faire fonctionner la robinetterie qu'avec les filtres et clapets de non retour d'origine !
- DE Wichtige Hinweise**  
Vor Installation Rohrleitungen gemäß DIN 1988 spülen!  
Nach erfolgter Montage die Temperaturbegrenzung einstellen!  
Armatür nur mit original Sieben und Rückflussverhinderern betreiben!
- ES Indicaciones importantes**  
¡Enjuagar las tuberías antes de instalar!  
¡Ajuste el límite de temperatura tras realizar el montaje!  
¡La grifería debe hacerse funcionar únicamente con los tamices y las válvulas antiretorno originales!
- CS Důležité pokyny**  
Před instalací potrubí propláchněte!  
Po provedené montáži nastavte omezení teploty!  
Provozovat armaturu jen s originálními sítky a zařízeními proti zpětnému toku!
- NL Belangrijke aanwijzingen**  
Voor installatie buisleidingen spoelen!  
Na de montage de temperatuur-begrenzing instellen!  
Armatuur alleen met originele zeven en terugstroomkleppen gebruiken!
- PL Ważne wskazówki**  
Przed instalacją przepłukać rury!  
Po zakończeniu montażu ustawić ograniczenie temperatury!  
Armatury należy używać wyłącznie z oryginalnymi sitkami i zaworami zwrotnymi!
- SV Viktiga informationer**  
Spola igenom rörledningarna före installation!  
När monteringen har gjorts skall temperaturbegränsningen ställas in!  
Använd armaturen endast med originalsilar och originalåterflödesförhindrare!
- HU Fontos utasítások**  
Telepítés előtt öblítse át a csövezetékeket!  
Összeszerelést követően állítsa be a hőmérséklet-korlátozást!  
Az armatúrát kizárólag eredeti szűrőkkel és visszafolyás-gátlókkal üzemeltesse!
- FI Tärkeitä ohjeita**  
Huuhtelee putkijohdot ennen asennusta!  
Säädä asennuksen jälkeen lämpötilan rajoitus!  
Käytä varusteet vain alkuperäisten sihtien ja takaisin-virtauksen eston kanssa!
- EL Σημαντικές οδηγίες**  
Πριν από την εγκατάσταση ξεπλύνετε τις σωληνώσεις!  
Αφού γίνει η συναρμολόγηση ρυθμίστε το όριο της θερμοκρασίας!  
Η μπαταρία να λειτουργεί μόνο με γνήσια κόσκινα και συστήματα ανάσχεσης της αναρροής!
- IT Avvertenze importanti**  
Sciacquare le tubazioni prima di installare!  
Una volta terminata l'installazione, impostare la limitazione di temperatura!  
Utilizzare la rubinetteria esclusivamente con i filtri e le valvole antiriflusso originali!
- RU Важные указания**  
Перед инсталляцией промыть трубки!  
После монтажа отрегулировать температурный предел!  
Эксплуатировать арматуру только с оригинальными фильтрами и клапанами обратного течения!
- RO Indicații importante**  
A se spăla conductele de țevi înainte instalatiei!  
A se regla limitarea temperaturii după montarea efectuată!  
A nu se lua în funcțiune armătura decât cu site originale și cu clapete antiretur!

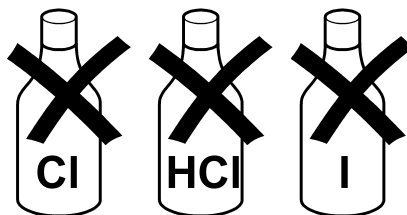
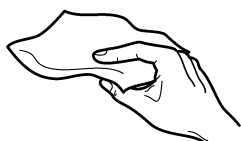
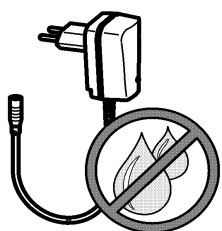

[www.franke.com](http://www.franke.com)  
[www.franke.de](http://www.franke.de)

<b>EN</b> Technical data		<b>FR</b> Données techniques	
Minimum flow pressure	1,0 bar	Pression dynamique minimale	1,0 bar
Maximum operating pressure	10 bar	Pression de service maximale	10 bars
Recommended flow pressure	3 bar	Pression dynamique recommandée	3 bars
Volume flow	0,10 l/s	Débit volumique	0,10 l/s
Supply voltage	100-240 V AC	Tension de raccordement	100-240 V AC
Type of protection	IP 55 / IP 22	Type de protection	IP 55 / IP 22
Operating voltage	6 V DC	Tension de service	6 V DC
<b>DE</b> Technische Daten		<b>ES</b> Datos técnicos	
Mindestfließdruck	1,0 bar	Presión mínima de flujo	1,0 bar
Maximaler Betriebsdruck	10 bar	Presión máxima de servicio	10 bares
Empfohlener Fließdruck	3 bar	Presión de flujo recomendada	3 bares
Volumenstrom bei 3 bar Fließdruck	0,10 l/s	Flujo volumétrico	0,10 l/s
Anschlussspannung	100-240 V AC	Tensión de conexión	100-240 V AC
Schutzart	IP 55 / IP 22	Modo de protección	IP 55 / IP 22
Betriebsspannung	6 V DC	Tensión de servicio	6 V CC
<b>NL</b> Technische gegevens		<b>PL</b> Dane techniczne	
Minimale dynamische druk	1,0 bar	Minimalne ciśnienie przepływu	1,0 bar
Maximale werkdruk	10 bar	Maksymalne ciśnienie robocze	10 barów
Aanbevolen dynamische druk	3 bar	Zalecane ciśnienie przepływu	3 barów
Volumestroom	0,10 l/s	Objętościowe natężenie przepływu	0,10 l/s
Aansluitspanning	100-240 V AC	Napięcie przyłączeniowe	100-240 V AC
Veiligheidsgraad	IP 55 / IP 22	Rodzaj ochrony	IP 55 / IP 22
Bedrijfsspanning	6 V DC	Napięcie robocz	6 V DC
<b>SV</b> Tekniska data		<b>FI</b> Tekniset tiedot	
Minsta hydrauliska tryck	1,0 bar	Vähimmäisvirtauspaine	1,0 bar
Maximalt drifttryck	10 bar	Suurin käyttöpain	10 bar
Rekommenderat hydrauliskt tryck	3 bar	Suosittelava virtauspaine	3 bar
Volymström	0,10 l/s	Tilavuusvirta	0,10 l/s
Anslutningsspänning	100-240 V AC	Verkköjännite	100-240 V AC
Skyddsklass	IP 55 / IP 22	Suojaustapa	IP 55 / IP 22
Driftspänning	6 V DC	Käyttöjännite	6 V DC
<b>IT</b> Specifiche tecniche		<b>RU</b> Технические характеристики	
Pressione idraulica min.	1,0 bar	Минимальный гидравлический напор	1,0 бар
Pressione di esercizio max.	10 bar	Максимальное рабочее давление	10 бар
Pressione idraulica consigliata	3 bar	Рекомендуемый гидравлический напор	3 бар
Portata volumetrica	0,10 l/s	Объемный расход	0,10 л/сек
Tensione di allacciamento	100-240 V AC	Напряжение питающей сети	100-240 В переменного тока
Tipo di protezione	IP 55 / IP 22	Вид защиты	IP 55 / IP 22
Tensione di esercizio	6 V DC	рабочее напряжение	6 В постоянного тока
<b>CS</b> Technické údaje		<b>HU</b> Műszaki adatok	
Minimální průtočný tlak	1,0 bar	Minimális áramlási nyomás	1,0 bar
Maximální provozní tlak	10 bar	Maximális üzemi nyomás	10 bar
Doporučený průtočný tlak	3 bar	Javasolt áramlási nyomás	3 bar
Průtok	0,10 l/s	Volumenáram	0,10 l/s
Přípojné napětí	100-240 V AC	Csatlakozási feszültség	100-240 V AC
Krytí	IP 55 / IP 22	Védelem típusa	IP 55 / IP 22
Provozní napětí	6 V DC	Üzemi feszültség	6 V DC
<b>EL</b> Τεχνικά στοιχεία		<b>RO</b> Datele tehnice	
Ελάχιστη πίεση ροής	1,0 bar	Presiune minimă a curgerii	1,0 bar
Μέγιστη πίεση λειτουργίας	10 bar	Presiune maximă de funcționare	10 bari
Προτεινόμενη πίεση ροής	3 bar	Presiune de curgere recomandată	3 bari
Ρυθμός ογκομετρικής παροχής	0,10 l/s	Fluxul volumic	0,10 l/s
Τάση σύνδεσης	100-240 V AC	Tensiune de alimentare	100-240 V AC
Είδος προστασίας	IP 55 / IP 22	Grad de protecție	IP 55 / IP 22
Τάση λειτουργίας	6 V DC	Tensiunea de funcționare	6 V DC

# Montage

EN Installation  
FR Montage  
ES Montaje  
CS Montáž

NL Montage  
PL Montaż  
SV Montering  
HU Szerelés  
FI Asennus

EL Συναρμολόγηση  
IT Montaggio  
RU Монтаж  
RO Montaj

 13 mm

 19 mm

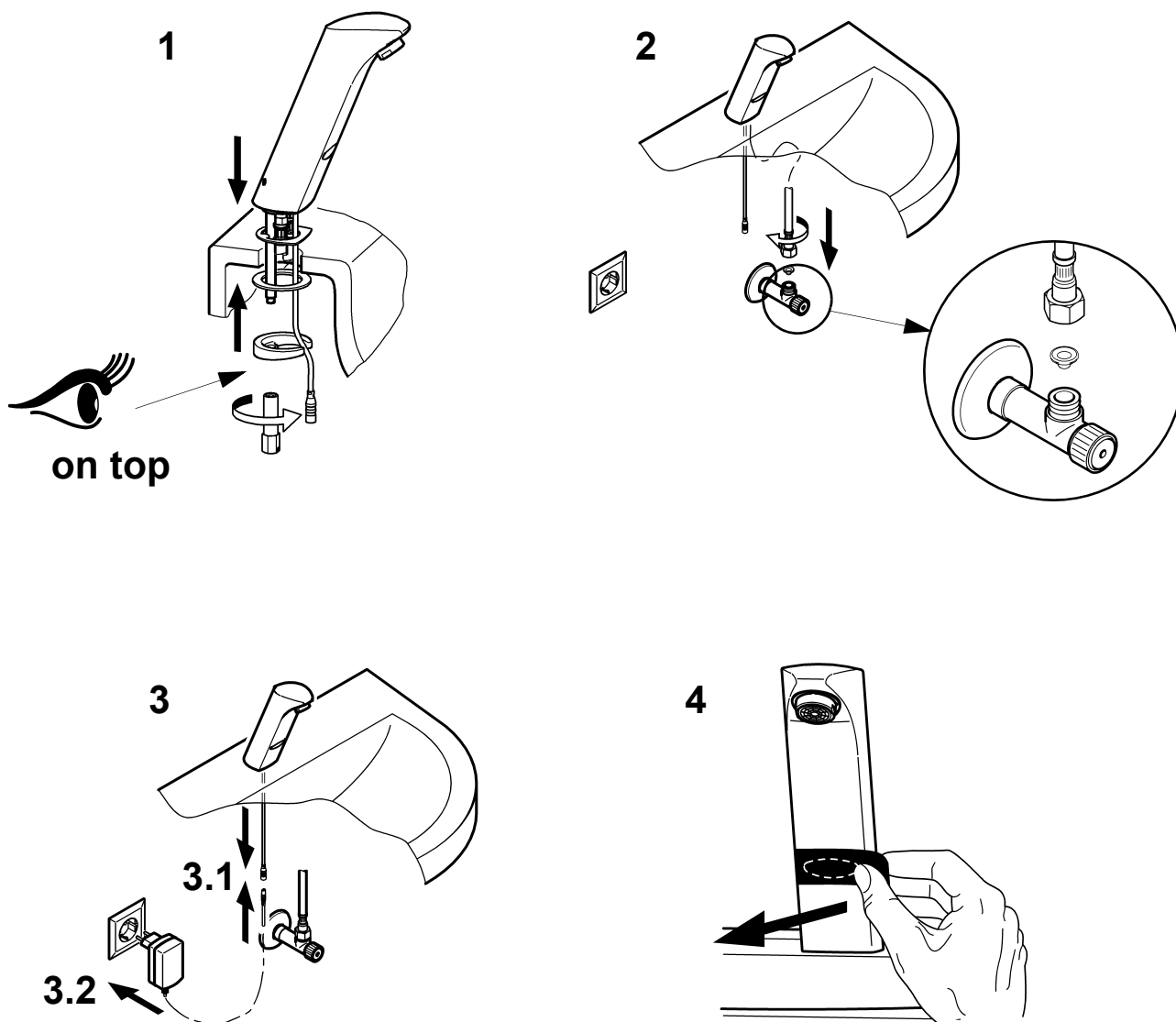

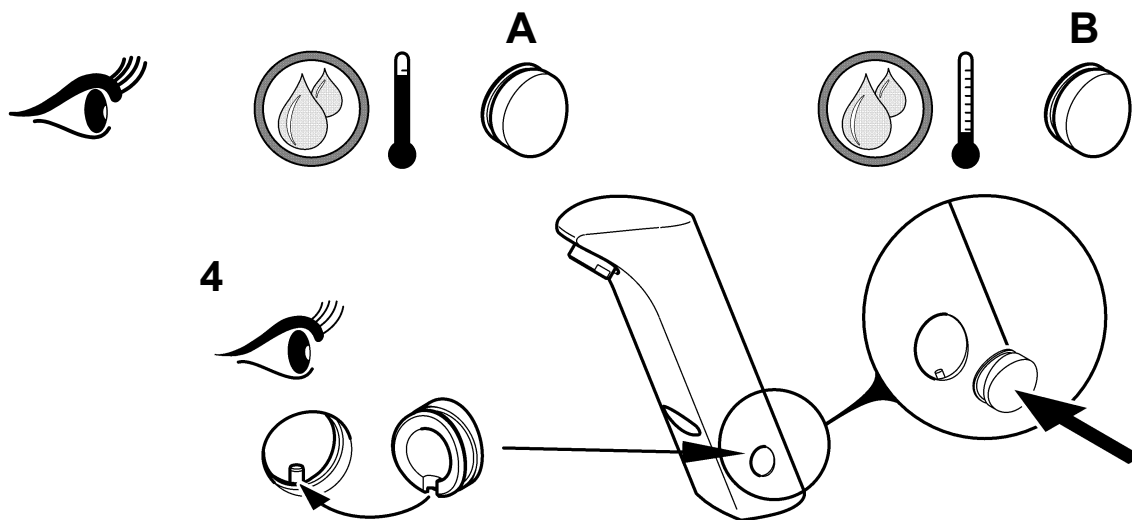

EN A Red B Blue	FR A Rouge B Bleu	DE A Rot B Blau	ES A Rojo B Azul	CS A Červený B Modrý
NL A Rood B Blauw	PL A Czerwony B Niebieski	SV A Röd B Blå	HU A Piros B Kék	FI A Punainen B Sininen
EL A Κόκκινο B Μπλε	IT A Rosso B Blu	RU A красный B голубой	RO A Roșu B Albastru	

## Funktion

EN Function	NL Werking	EL λειτουργία
FR Fonctionnement	PL Funkcja	IT Funzionamento
ES Función	SV Funktion	RU Функционирование
CS Funkce	HU Funkció	RO funcție
	FI Toiminto	

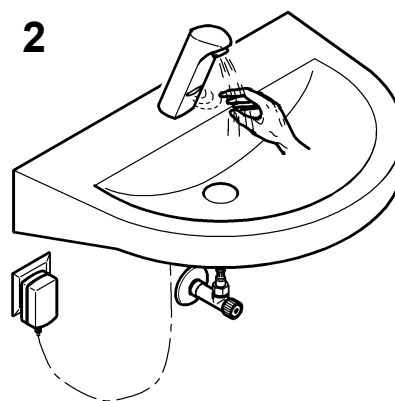
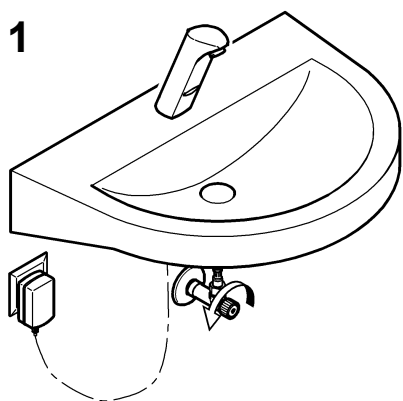

# Anzeige: letzter Spülvorgang in Stunden

<b>EN</b> Display: Last flush-process in hours	<b>NL</b> Weergave: laatste spoelprocedure in uren	<b>EL</b> Ένδειξη: τελευταία διαδικασία πλύσης σε ώρες
<b>FR</b> Affichage: dernière opération de rinçage en heures	<b>PL</b> Informacja: ostatnie splukiwanie w godzinach	<b>IT</b> Indicazione: ultimo sciacquo in ore
<b>ES</b> Indicación: último proceso de aclarado en hora	<b>SV</b> ndikering: Sista sköljning i timmar	<b>RU</b> На дисплее: последний смывной процесс в часах
<b>CS</b> Upozornění: poslední vypláchnutí v hodinách	<b>HU</b> Értésítés: az utolsó öblítési folyamat órában megadva	<b>RO</b> Afişaj: ultimul proces de spălare, exprimat în ore
	<b>FI</b> Näyttö: viimeisin huuhtelutapahtuma tunteina	

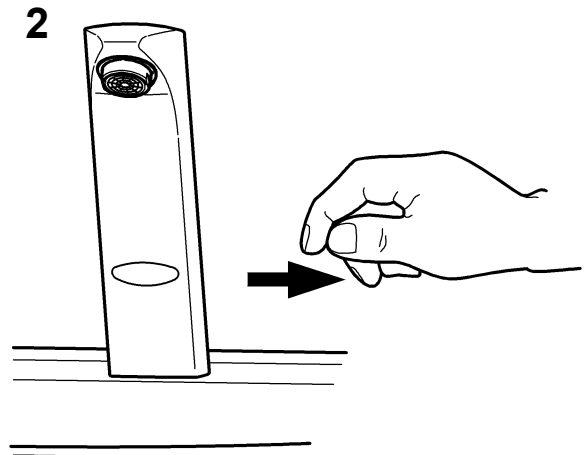
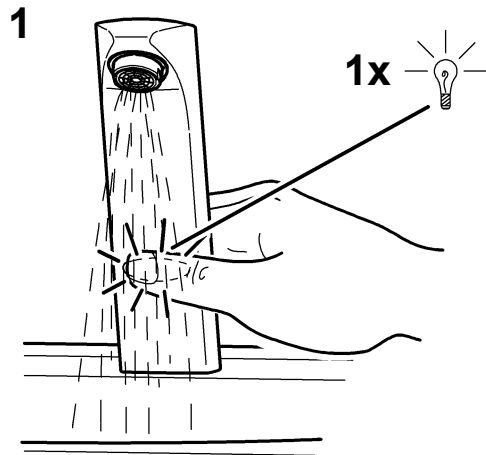

<b>3x =</b>	<b>30 h</b>	+	<b>4x =</b>	<b>4 h</b>	=	<b>34 h</b>
—	—	—	—	—	—	—
1x = 10 h	1x = 1 h		1x = 1 h			
2x = 20 h	2x = 2 h		2x = 2 h			
3x = 30 h	3x = 3 h		3x = 3 h			
...	...		...			
9x = 90 h	9x = 9 h					

<b>0x =</b>	<b>00 h</b>	+	<b>0x =</b>	<b>0 h</b>	=	<b>&lt; 59 min</b>
—	—	—	—	—	—	—
1x = 10 h	1x = 1 h		1x = 1 h			
2x = 20 h	2x = 2 h		2x = 2 h			
3x = 30 h	3x = 3 h		3x = 3 h			
...	...		...			
9x = 90 h	9x = 9 h		9x = 9 h			

# Anzeige: Status Hygienespülung

EN Display: Status hygiene flushing

FR Affichage : état rinçage hygiénique

ES Indicación: estado del enjuague de higiene

CS Indikátor: stav hygienického omytí

NL Aanduiding: Status hygiënespoeling

PL Wyświetlacz: status splukiwania higienicznego

SV Indikering: Status hygiensköljning

HU Kijelző: Higiéniai öblítés állapot

FI Näyttö: hygieniahuuhtelun tilanne

EL Ένδειξη: Κατάσταση υγιεινής πλύσης

IT Indicazione: stato sciacquo igienico

RU Индикатор: состояние гигиенической мойки

RO Indicator: statut de spălat igienic

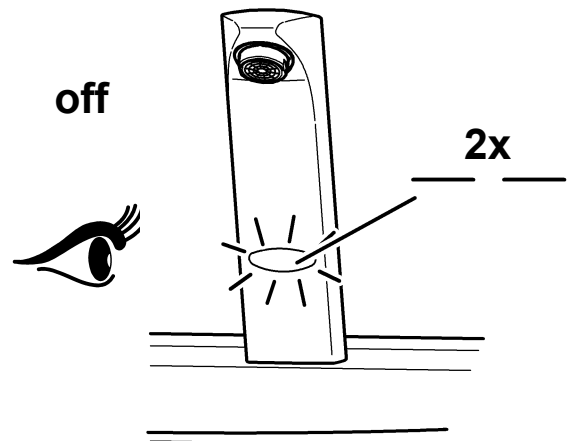
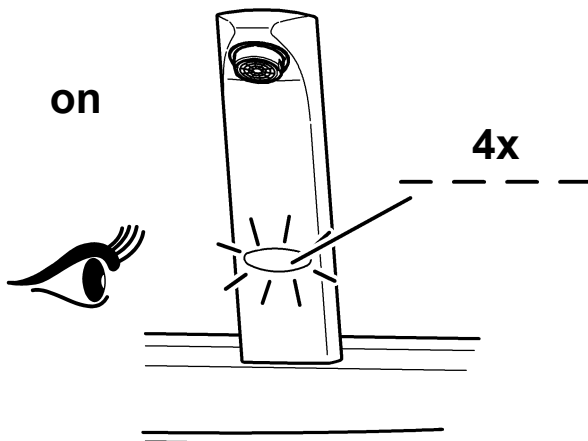
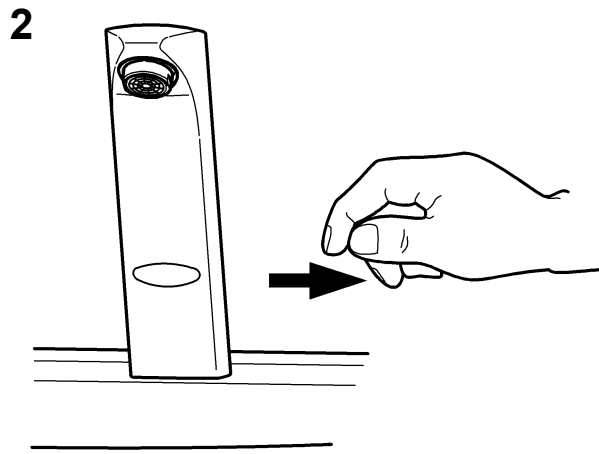
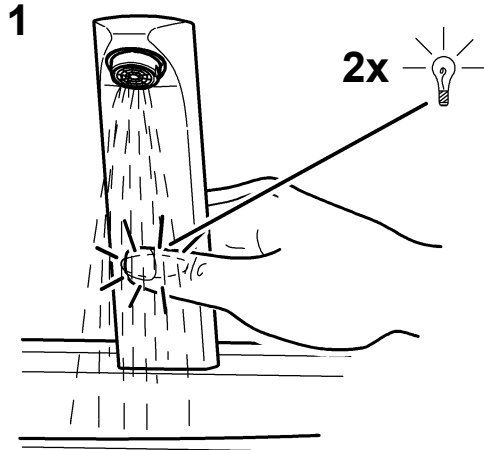

# Armatur ausschalten

EN Switch off the valve  
 FR Désactiver la robinetterie  
 ES Desconectar la grifería  
 CS Vypnout armaturu

NL Armatuur uitschakelen  
 PL Wyłączenie baterii  
 SV Avstängning av armatur  
 HU Armatúra kikapcsolása  
 FI Laitteen kytkeminen pois päältä

EL Απενεργοποίηση μπαταρίας  
 IT Disattivazione della rubinetteria  
 RU отключить оборудование  
 RO A se opri armătura

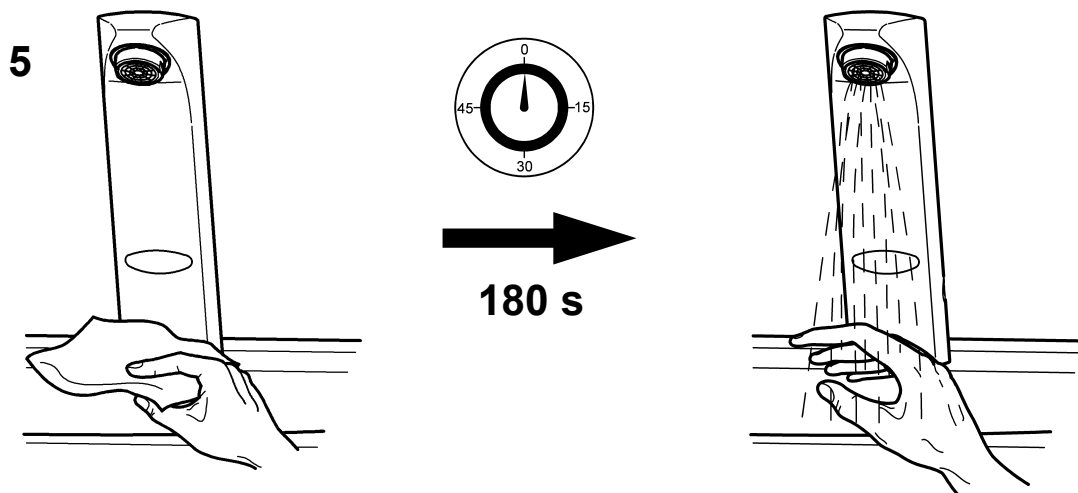
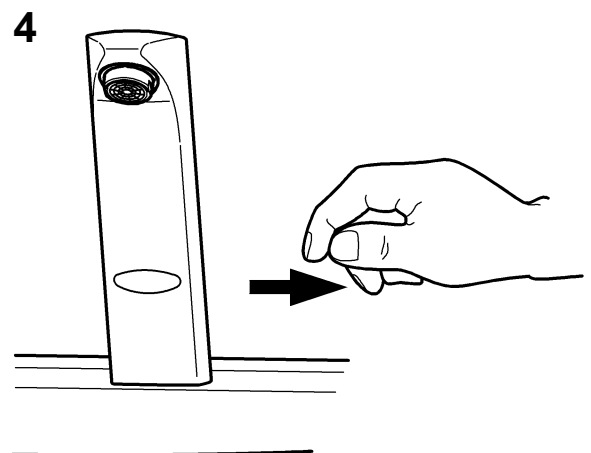
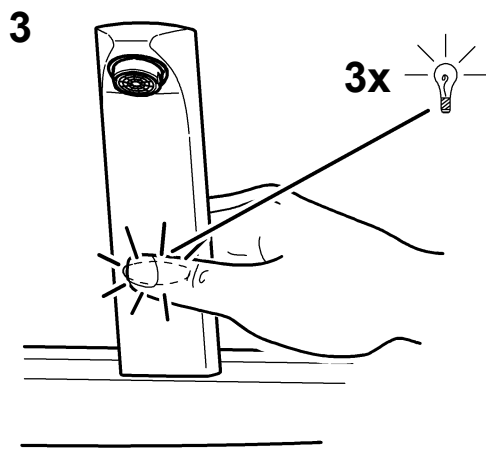
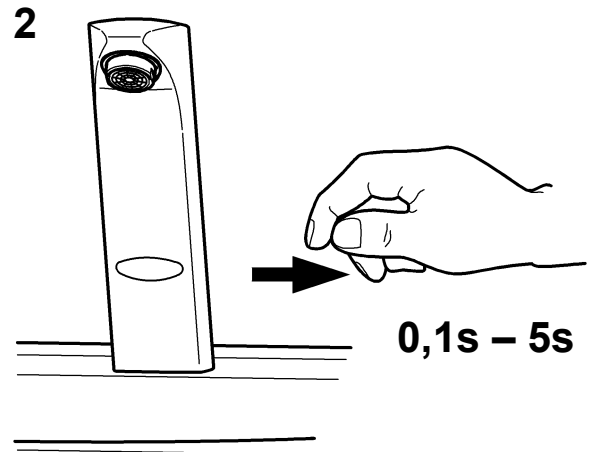
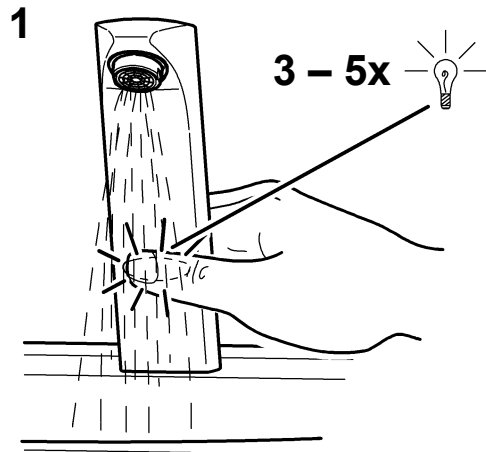



# Dauerlauf starten

EN Start continual flow  
 FR Démarrer la marche continue  
 ES Iniciar el enjuague continuo  
 CS Spustit trvalý provoz

NL Continue stroming starten  
 PL Uruchomić stały wypływ wody  
 SV Starta kontinuerlig drift  
 HU Folyamatos futás indítása  
 FI Tuotantokäytön aloittaminen

EL Εκκίνηση διαρκούς ροής  
 IT Avviare l'erogazione continua  
 RU запустить ресурс  
 RO A se porni rularea permanentă

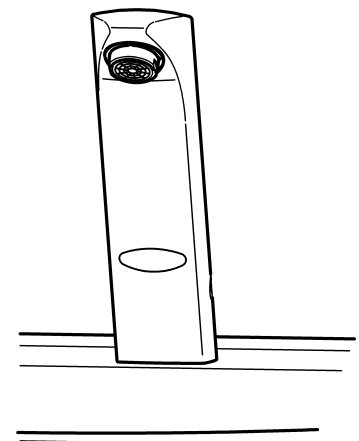
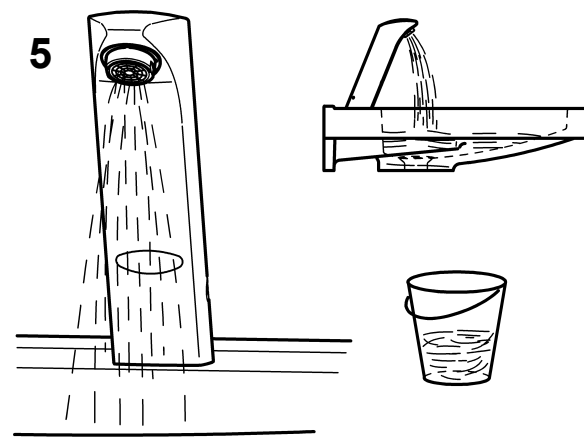
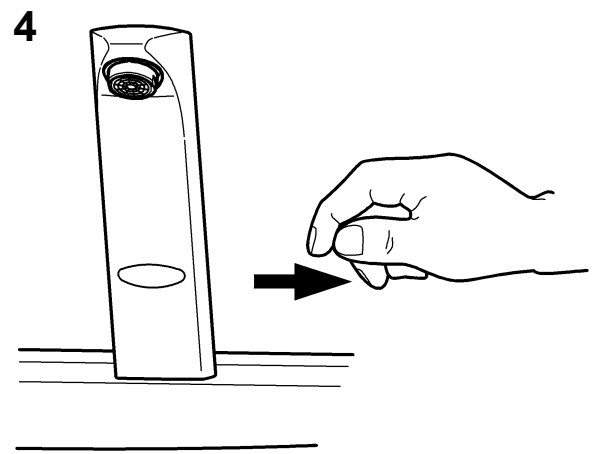
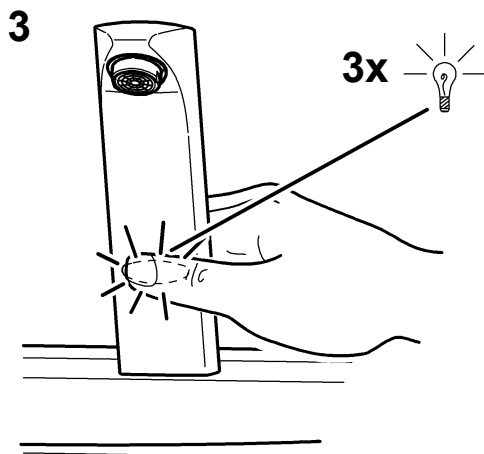
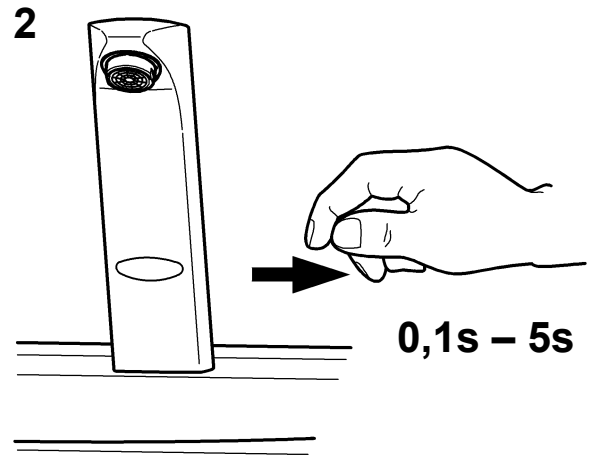
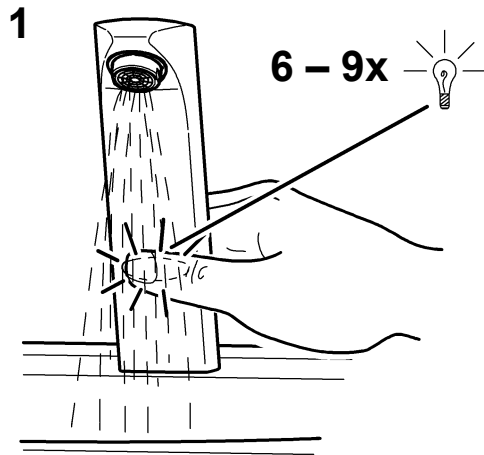

# Hygienespülung ein- / ausschalten

<b>EN</b> Switching hygiene flushing on/off	<b>NL</b> Hygiënische spoeling in-/uitschakelen	<b>EL</b> Ενεργοποίηση/απενεργοποίηση υγιεινής πλύσης
<b>FR</b> Activer/désactiver le rinçage hygiénique	<b>PL</b> Włączyć/wyłączyć splukiwanie higieniczne	<b>IT</b> Attivare/disattivare lo sciacquo igienico
<b>ES</b> Activar/Desactivar el aclarado higiénico	<b>SV</b> Koppla hygienspolningen till / från	<b>RU</b> Гигиеническое промывание включить/выключить
<b>CS</b> Zapněte/vypněte hygienické propíchnutí	<b>HU</b> Higiénias öblítés be-/ ki-kapcsolása	<b>RO</b> Pornit/oprit clătire igienica
	<b>FI</b> HygieniahuuhTELun päälle-/ pois päältä kytkeminen	

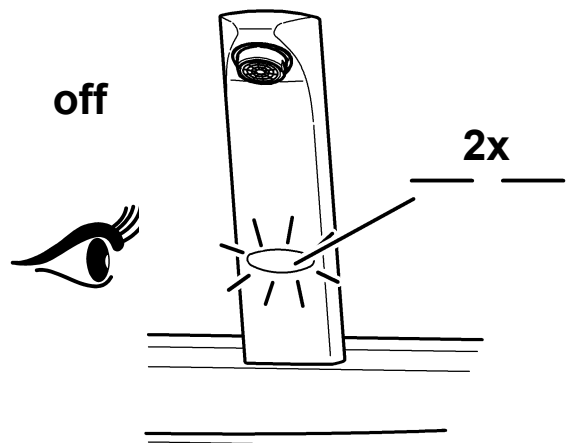
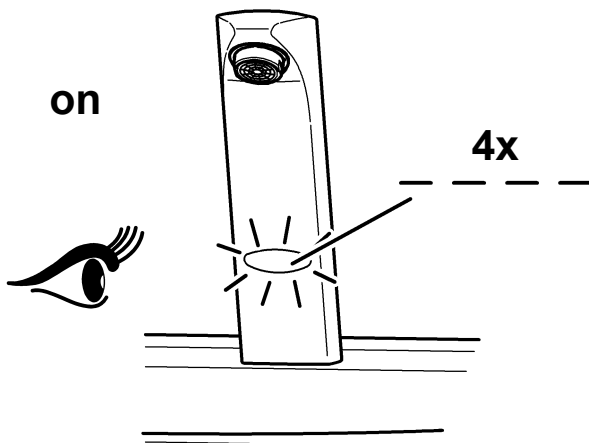
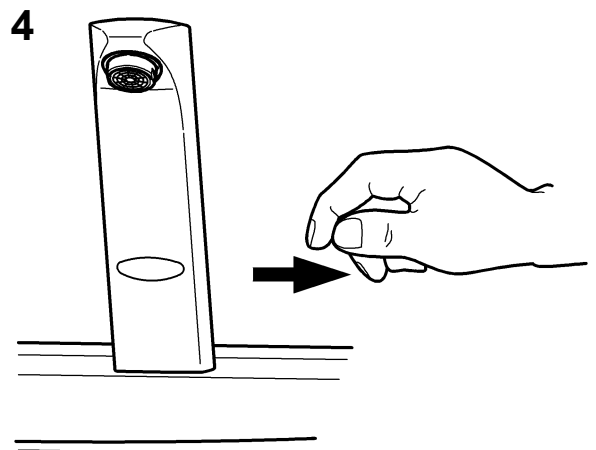
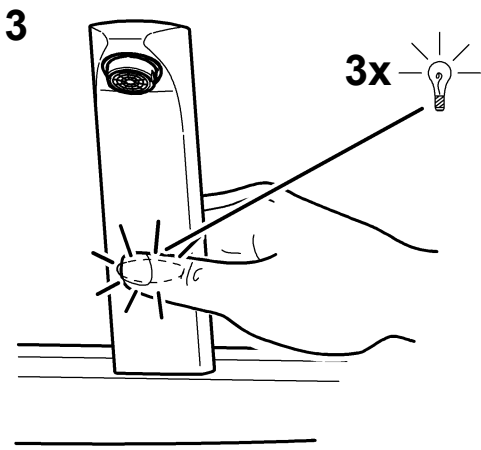
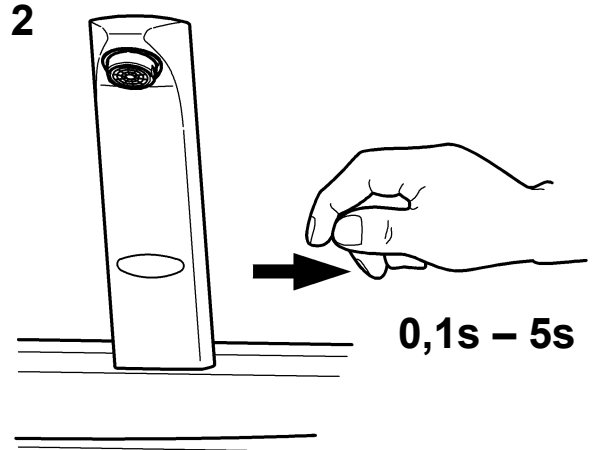
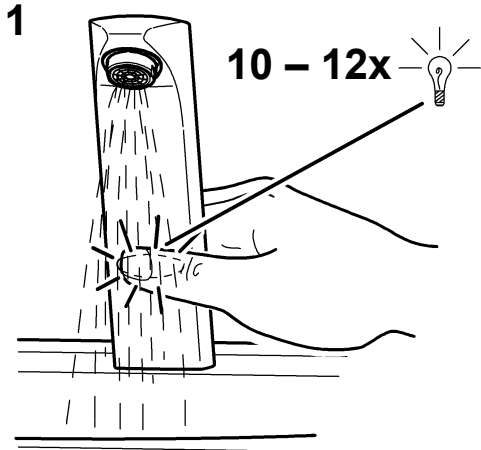

ZMI\_001\_2030025088-PRTRS0011\_#SALL\_#AQU\_#V1.fm

<b>EN</b> Ensure open outlet. After 24h of non-use, water flows 10 sec.	<b>NL</b> Vrije uitloop garanderen. Na 24 uur niet te zijn gebruikt stroomt er gedurende 10 sec. water.	<b>EL</b> Εξασφαλίστε ανεμπόδιστη εκροή. Εάν δεν χρησιμοποιηθεί επί 24 ώρες, θα ρεύσει νερό επί 10 δευτερόλεπτα.
<b>FR</b> Garantir un écoulement libre. L'eau s'écoule pendant 10 sec. après 24h de non utilisation.	<b>PL</b> Zapewnić swobodny wylot. Po 24 godz. niekorzystania przez 10 s. wypływa woda.	<b>IT</b> Garantire l'erogazione libera. Dopo 24h di inutilizzo scorre acqua per 10 sec.
<b>DE</b> Freien Auslauf gewährleisten. Nach 24h Nichtbenutzung fließt 10 sec Wasser.	<b>SV</b> Garantera fritt avlopp. Vatten flyter 10 sek efter 24 timmars användningspaus.	<b>RU</b> Обеспечить беспрепятственный слив После того, как устройство не используется в течение 24 ч, в течение 10 сек течёт вода.
<b>ES</b> Garantizar una salida libre. Si no se realiza ningún uso durante 24 horas, fluye agua durante 10 segundos.	<b>HU</b> Szabad kifolyás biztosítása. Minden használat nélkül eltelt 24 ó után 10 mp-ig folyik a víz.	<b>RO</b> A se asigura o scurgere libera. Daca nu se foloseste timp de 24 ore, a se lasa apa sa se scurga timp de 10 s.
<b>CS</b> Zajistěte volný odtok. Při nepoužívání 24 h nechte 10 s téct vodu.	<b>FI</b> Vapaa virtauksen takaaminen. Käyttämättömänä 24 h jälkeen virtaa vettä 10 s	

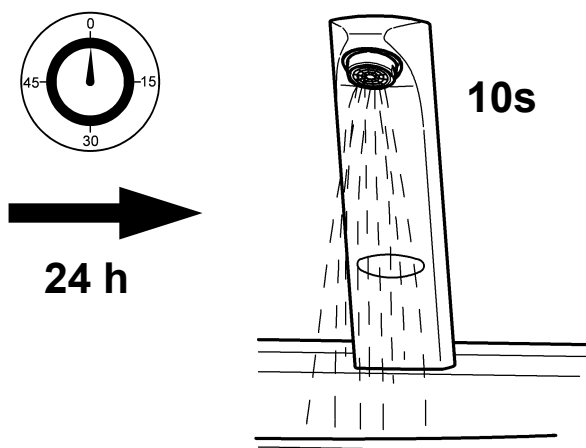

# Erfassungsart ändern

EN Change type of detection  
FR Modifier le type de détection  
ES Modificar el tipo de captación  
CS Změnit způsob snímání

NL Registratiesoort wijzigen  
PL Zmiana rodzaju wykrywania  
SV Registreringssätt  
HU Érzékelés módja  
FI Mittaustyyppin muuttaminen

EL Αλλαγή τρόπου ανίχνευσης  
IT Modificare il tipo di rilevamento  
RU Способ считывания  
RO Modificare mod de scanare

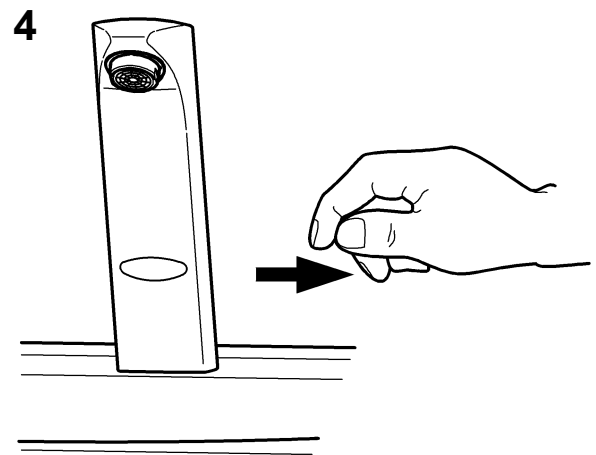
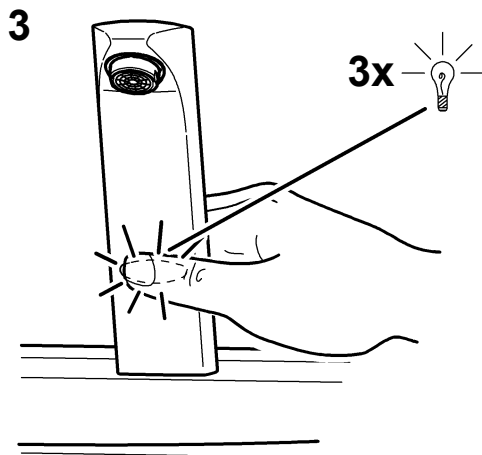
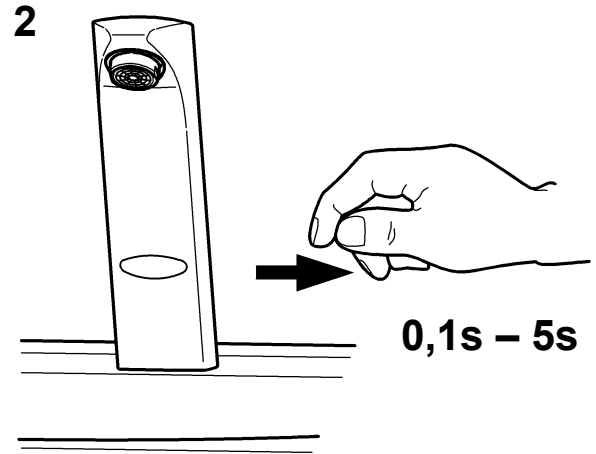
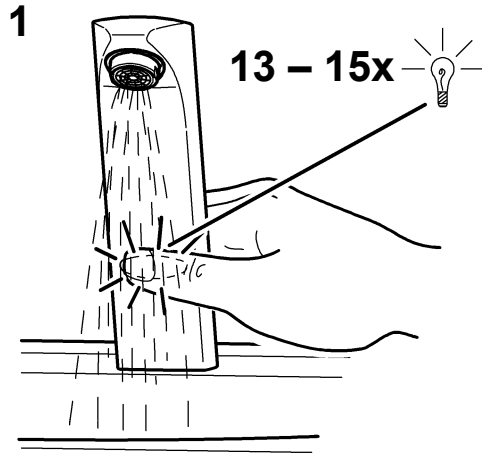

<b>EN</b>	Type of detection	The sensor is detecting
A	static	Object
B	dynamic	Movement (with intense reflections from basin)

<b>FR</b>	Type de détection	Le capteur détecte
A	statique	Objet
B	dynamique	Mouvement par forte réflexion du bassin

<b>DE</b>	Erfassungsart	Der Sensor erfasst
A	statisch	Objekt
B	dynamisch	Bewegung (bei hoher Beckenreflexion)

<b>ES</b>	Tipo de captación	El sensor está captando
A	estático	Objeto
B	dinámico	Movimiento (en caso de elevada reflexión en el lavabo)

<b>NL</b>	Registratiesoort	De sensor registreert
A	statisch	Object
B	dynamisch	Beweging (bij hogere reservoirreflectie)

<b>PL</b>	Rodzaj wykrywania	Czujnik rejestruje
A	statisch	Obiekt
B	dynamisch	Ruch (przy dużym odbiciu fali od umywalki)

<b>SV</b>	Registreringsätt	Sensor registrerar
A	statisk	Objekt
B	dynamisk	Rörelse (vid hög bäckenreflexion)

<b>FI</b>	Mittautyyppi	Anturi mittaa
A	staattinen	Kohde
B	dynaminen	Liike (suurella allasheijastuksella)

<b>IT</b>	Tipo di rilevamento	Il sensore rileva
A	statico	Oggetto
B	dinamico	Movimento (in caso di alta riflessione del lavabo)

<b>RU</b>	Способ считывания	Датчик считывает
A	статический	Объект
B	динамический	Движение (при большом отражении умывальника)

<b>CS</b>	Způsob snímání	Snímač snímá
A	statický	Objekt
B	dynamický	Pohyb (při vysokém odrazu umyvadla)

<b>HU</b>	Érzékelés módja	A szenzor érzékel
A	statikus	Tárgy
B	dinamikus	Mozgás (erős medence-visszaverődés esetén)

<b>EL</b>	Τρόπος ανίχνευσης	Ο αισθητήρας ανιχνεύει
A	στατικός	Αντικείμενο
B	δυναμικός	Κίνηση (με νιπτήρες υψηλής ανακλαστικότητα)

<b>RO</b>	Mod de scanare	Senzorul scanează
A	static	Obiect
B	dinamic	Mișcare (când reflexia chiuvetei este mare)

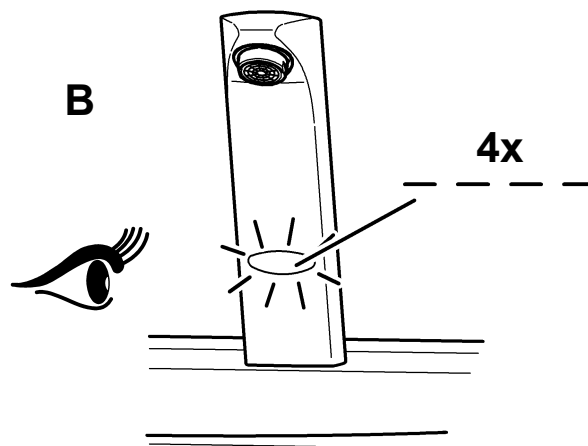
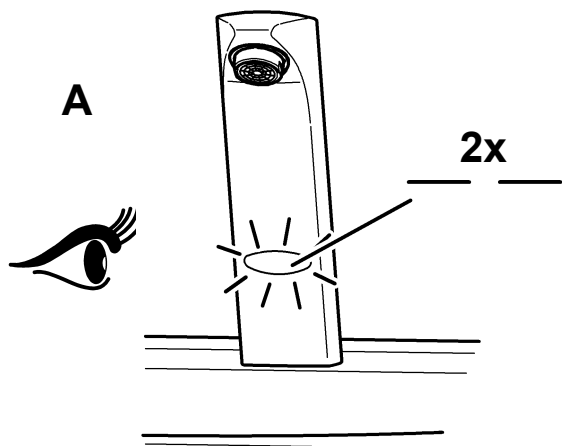

# Wartung

EN Maintenance  
FR Maintenance  
ES Mantenimiento  
CS Varování

NL Onderhoud  
PL Konserwacja  
SV Underhåll  
HU Figyelmeztetés  
FI Huolto

EL Προεidoποίηση  
IT Manutenzione  
RU Техническое обслуживание  
RO Avertisment

 19 mm

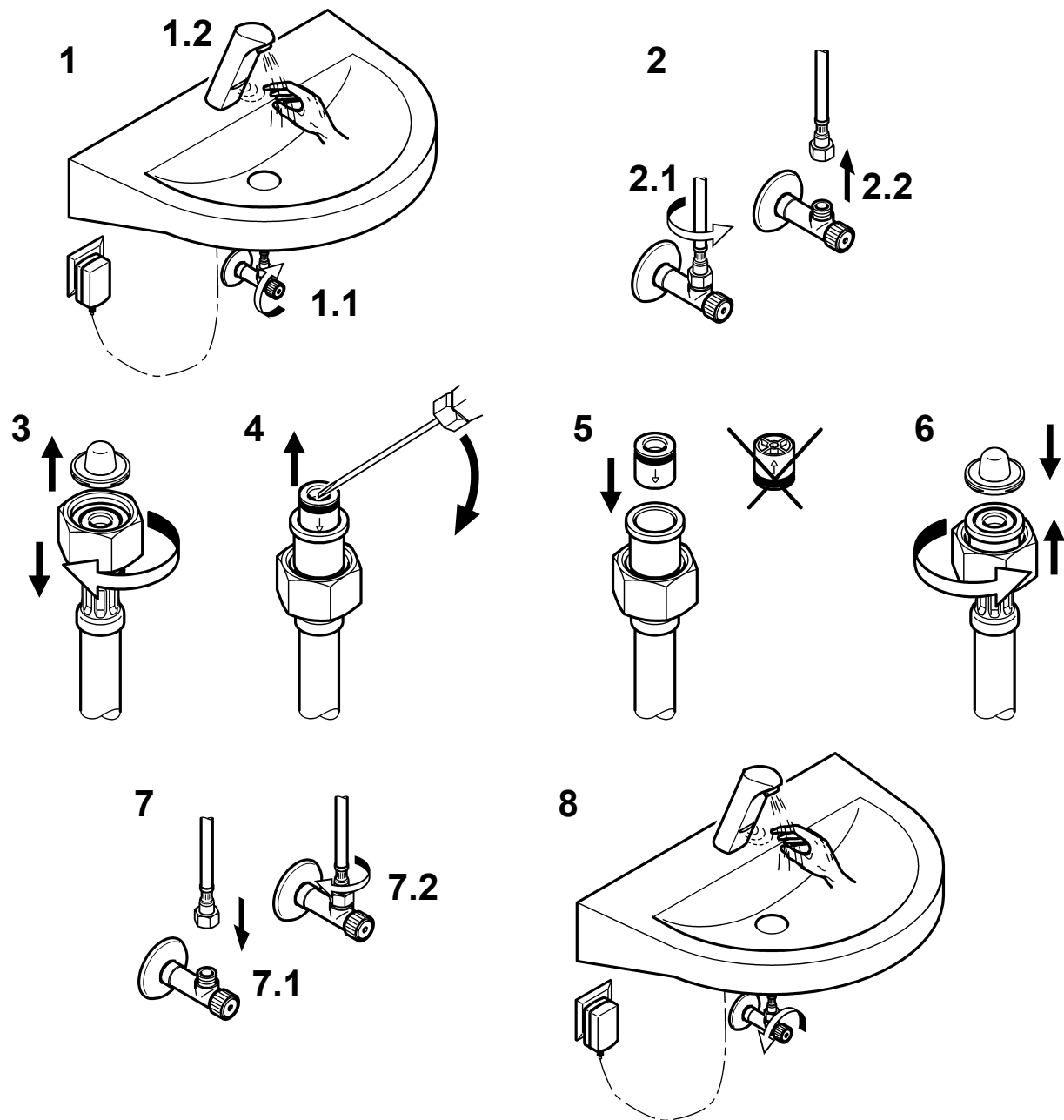

 22 mm

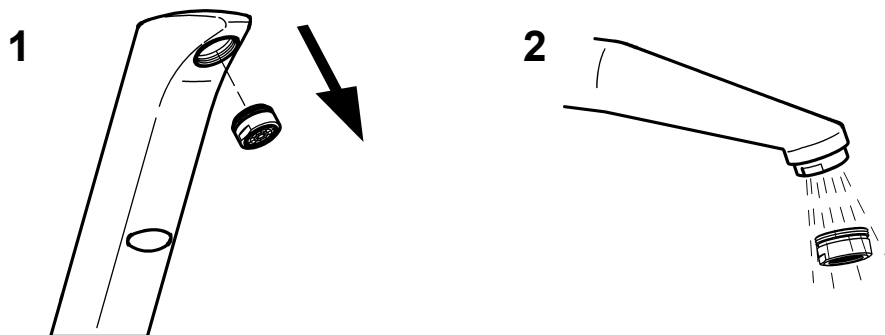

# Funktionsteil ausbauen

EN Remove functional part  
FR Démontér l'élément fonctionnel  
ES Desmontar la pieza funcional  
CS Demontovat funkční díl

NL Functie-element demonteren  
PL Wymontować element funkcjonalny  
SV Bygga ut funktionsdelen  
HU Funkcionális elem kiszerelese  
FI Kunnossapito

EL Αφαίρεση τμήματος λειτουργίας  
IT Smontaggio dell'elemento funzionale  
RU Демонтаж функциональной детали  
RO A se demonta piesa funcțională

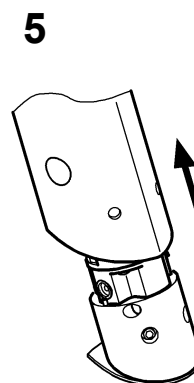
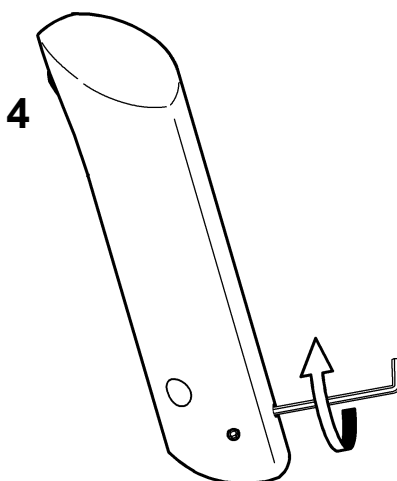
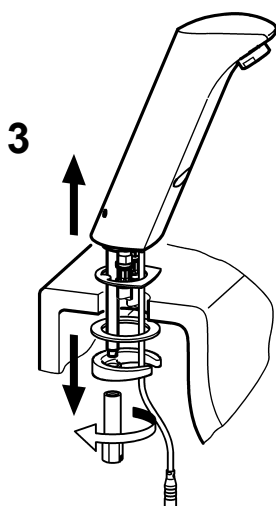
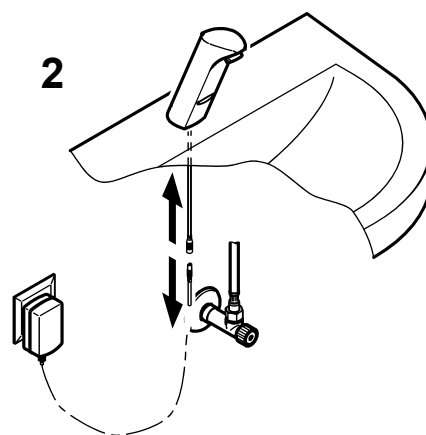
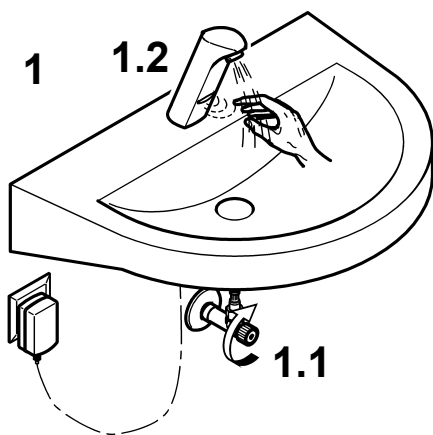
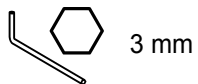

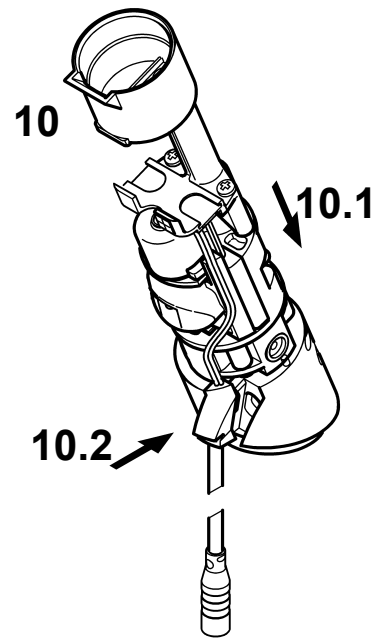
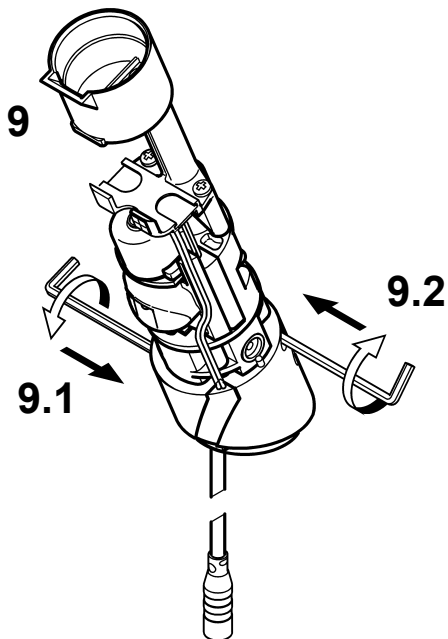
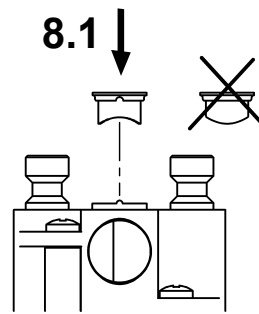
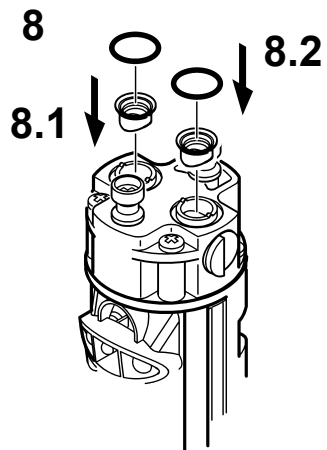
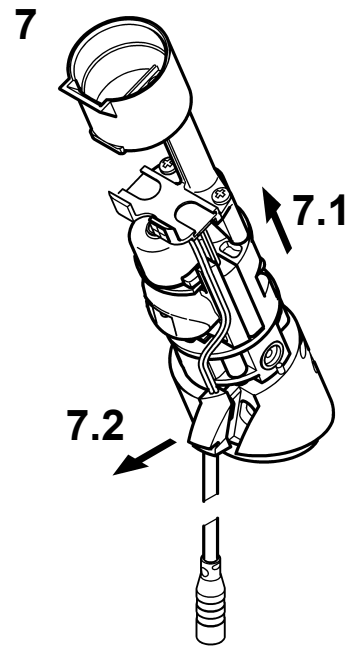
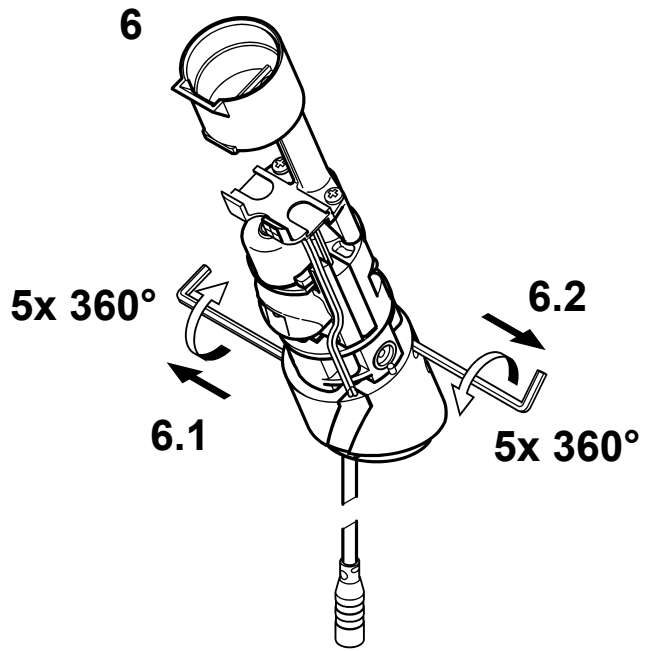



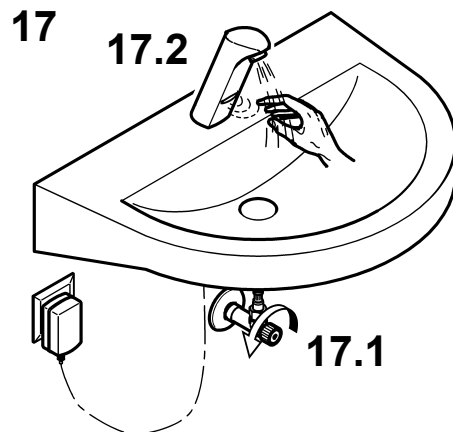
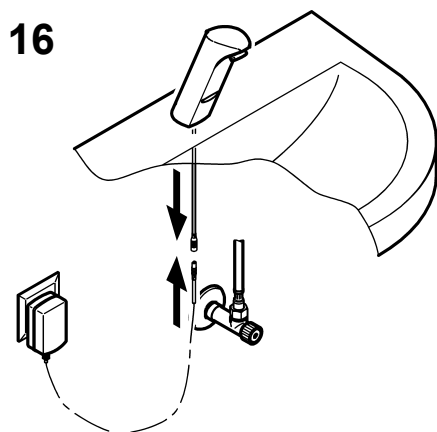
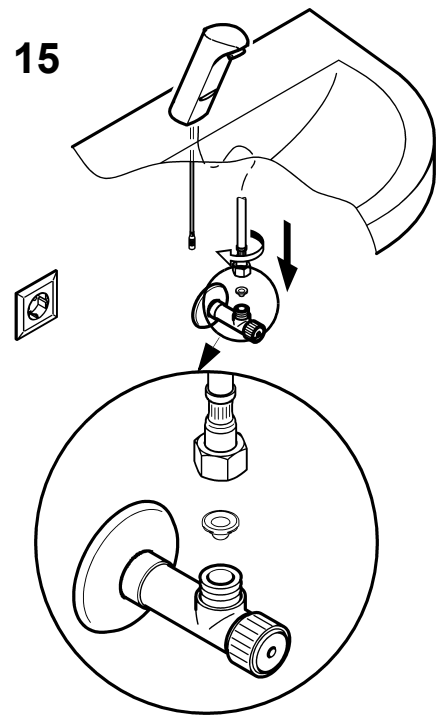
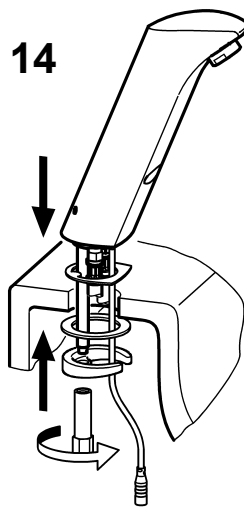
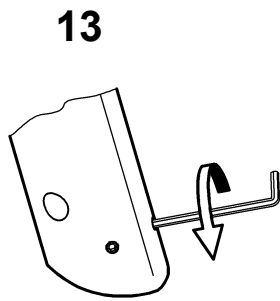
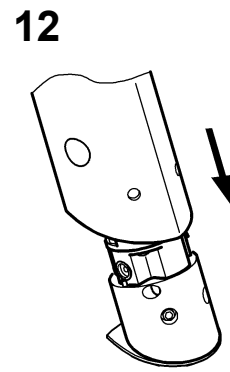
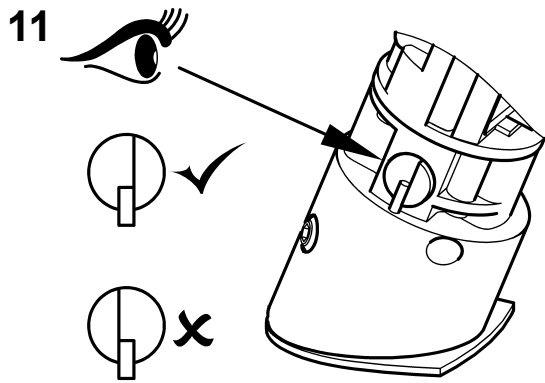

# Stopfen wechseln

EN Replacing the plug

FR Remplacement du bouchon

ES Sustituir el tapón

CS Výměna zátky

NL Stop vervangen

PL Wymienić zatyczkę

SV Byta plugg

HU Dugó cseréje

FI Vaihda tulppa

EL Αντικατάσταση πώματος

IT Sostituzione del tappo

RU Замена разъема

RO Înlouirea caracului

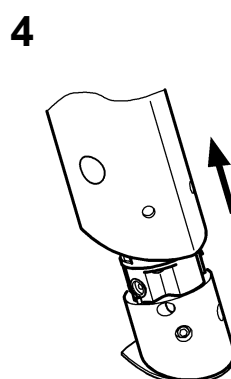
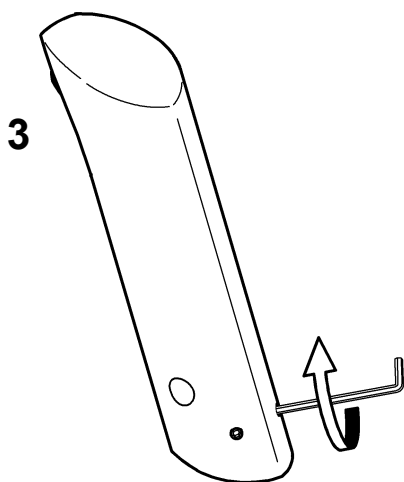
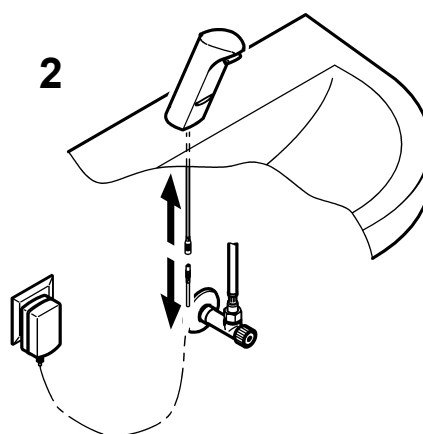
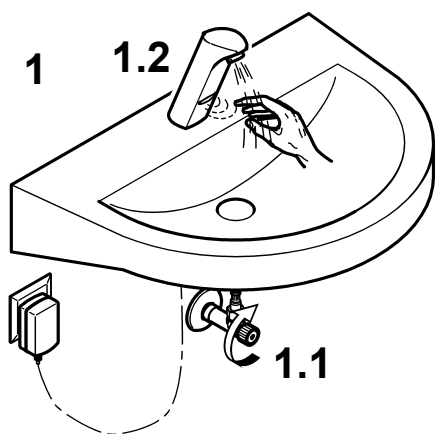
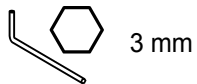

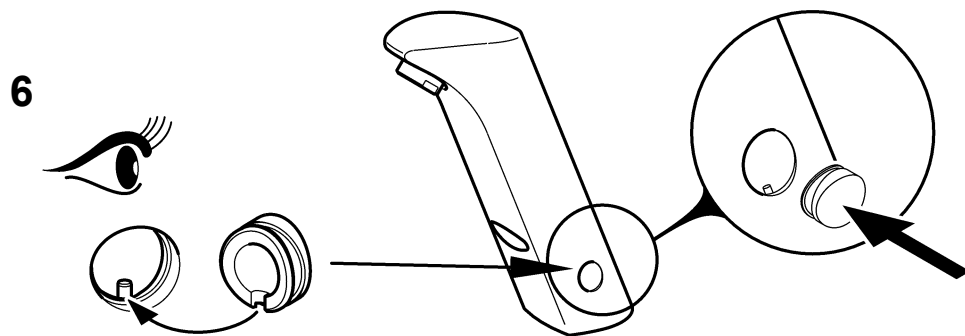
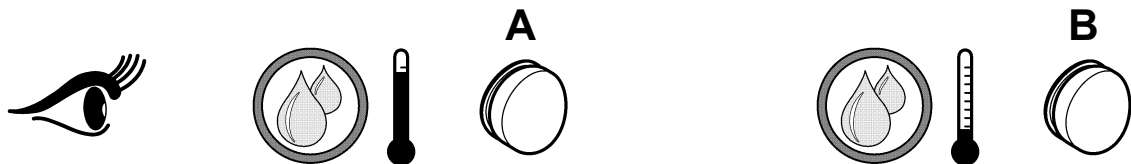
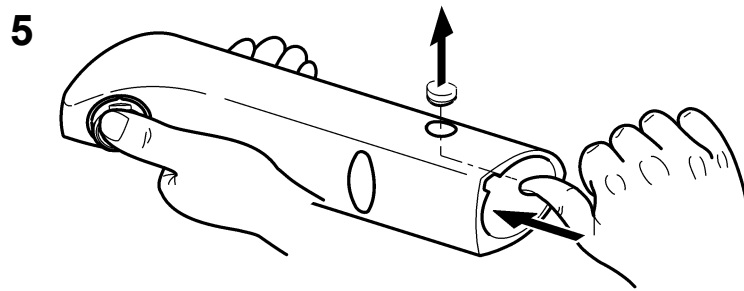

**EN** A Red  
B Blue

**FR** A Rouge  
B Bleu

**DE** A rot  
B Blau

**ES** A Rojo  
B Azul

**CS** A Červený  
B Modrý

**NL** A Rood  
B Blauw

**PL** A Czerwony  
B Niebieski

**SV** A Röd  
B Blå

**HU** A Piros  
B Kék

**FI** A Punainen  
B Sininen

**EL** A Κόκκινο  
B Μπλε

**IT** A Rosso  
B Blu

**RU** A красный  
B голубой

**RO** A Roșu  
B Albastru

# Ersatzteile

EN Replacement parts  
FR Pièces de rechange  
ES Piezas de recambio  
CS Náhradní díly

NL Reserveonderdelen  
PL Części zamienne  
SV Reservdelar  
HU Pótalkatrészek  
FI Varaosat

EL Ανταλλακτικά  
IT Pezzi di ricambio  
RU Запчасти  
RO Piese de schimb

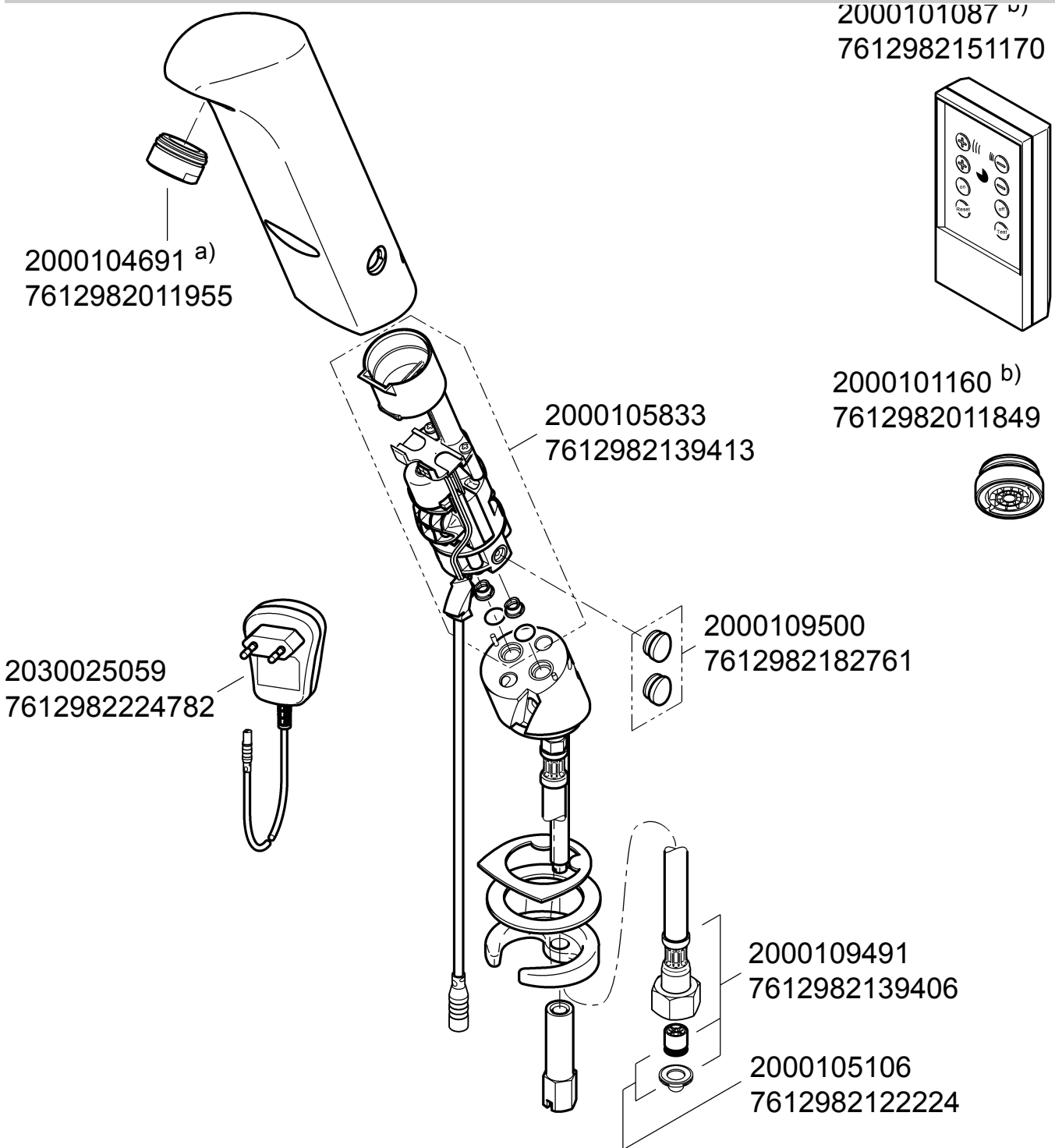

EN a) 10 pieces  
b) Accessories

NL a) 10 stuk  
b) Toebehoren

EL a) 10 τεμάχια  
b) Αξεσουάρ

FR a) 10 pièces  
b) Accessoire

PL a) 10 sztuk  
b) Akcesoria

IT a) 10 pezzi  
b) Accessori

DE a) 10 Stück  
b) Zubehör

SV a) 10 styck  
b) Tillbehör

RU a) 10 штук  
b) принадлежности

ES a) 10 piezas  
b) Accesorios

HU a) 10 darab  
b) Alkatrész

RO a) 10 bucăți  
b) Accesorii

CS a) 10 kusů  
b) Příslušenství

FI a) 10 kappaletta  
b) Varusteet

# WELL Public

## Water Efficiency Label

Hersteller: Franke Aquarotter GmbH  
 Produktkategorie: Waschtischarmatur  
 Typ: Zeit-/Sensorarmatur  
 Modell: PROTRONIC-S Kaltwasser  
 Registrierungsnummer: WA10542-20130228



### Wasser Effizienz Kriterien

Durchfluss > 6,0 l/min ≤ 9,0 l/min	*	
Durchfluss geregelt ≥ 4,0 l/min ≤ 6,0 l/min	**	←
Durchflussunabhängige Temperatureinstellung	*	
Temperaturbegrenzung / Kaltwasserventil	**	←
Selbstschlussarmatur	*	
Sensorarmatur	**	←

Informationen Betrieb und Montage: [www.well-online.eu](http://www.well-online.eu).  
 A Label of EUnited Valves  
 European Valve Manufacturers Association

# WELL Public

## Water Efficiency Label

Manufacturer: Franke Aquarotter GmbH  
Product category: Wash basin valve  
Type: Time/sensor valve  
Model: PROTRONIC-S Kaltwasser  
Registration number: WA10542-20130228



### Water Efficiency Criteria

Flow rate > 6,0 l/min ≤ 9,0 l/min	*
Controlled flow rate ≥ 4,0 l/min ≤ 6,0 l/min	**
Flow-independent temperature setting	*
Temperature limit / Cold water valve	**
Self-closing valve	*
Sensor valve	**

Information about use and installation: [www.well-online.eu](http://www.well-online.eu).

A Label of EUnited Valves

European Valve Manufacturers Association

# Notizen

**EN** Notes  
**FR** Notes  
**ES** Notas  
**CS** Poznámky

**NL** Notities  
**PL** Uwagi  
**SV** Notiser  
**HU** Jegyzetek  
**FI** Muistiinpanot

**EL** Παρατηρήσεις  
**IT** Annotazioni  
**RU** Примечания  
**RO** Notițe





**ALG**

SARL BFIX  
Résidence Chaabani  
Val d'Hydra part N°06-C Hydra 08  
DZ-16035 HYDRA-ALGER / Algeria  
t: +213 (0)21 60 13 60  
e: customer@bfixgroupe.com

**AUS**

PR Kitchen and Washroom Systems Pty Ltd  
83 Bangholme Road  
Dandenong South VIC 3175  
t: +61 (0)3 9700 9100  
e: info@prks.com.au

**AUT**

Franke GmbH  
Oberer Achdamm 52  
6971 Hard / Austria  
t: +43 (0)5574 6735 0  
e: ws-info.at@franke.com

**BEL**

Franke N.V.  
Ring 10  
9400 Ninove / Belgium  
t: +32 (0)54 310130  
e: ws-info.be@franke.com

**CAN**

Franke Kindred Canada Limited  
1000 Franke Kindred Road  
Midland, Ontario L4R 4K9 / Canada  
t: +1 855 446 5663  
e: ws-info.ca@franke.com

**CZE**

Franke Aquarotter GmbH  
Parkstrasse 1 - 5  
14974 Ludwigsfelde / Germany  
t: +420 281 090 429  
e: ws-info.cz@franke.com

**EGY**

Franke Kitchen Systems Egypt S.A.E.  
1st Industrial Zone  
6th October City, Cairo / Egypt  
t: +202 3828 0000  
e: ws-info.eg@franke.com

**FIN / SWE / NOR / DEN / EST**

Franke Finland Oy  
Vartiokujja 1  
76850 Naarajaervi / Finland  
t: +358 (0)15 3411 1  
e: ws-info.fi@franke.com

**FRA**

Franke GmbH  
Oberer Achdamm 52  
6971 Hard / Autriche  
t: 0800 909 216  
e: ws-info.fr@franke.com

**GBR / IRL**

Franke Sissons Ltd.  
Carrwood Road  
Chesterfield S41 9QB / United Kingdom  
t: +44 (0)1246 450 255  
e: ws-info.uk@franke.com

**GBR**

Dart Valley Systems Ltd.  
Kemings Close, Long Road,  
Paignton TQ4 7TW / United Kingdom  
t: +44 (0)1803 529 021  
e: sales@dartvalley.co.uk

**GER**

Franke Aquarotter GmbH  
Parkstrasse 1 - 5  
14974 Ludwigsfelde / Germany  
t: +49 (0)3378 818 0  
e: ws-info.de@franke.com

**GEO**

Franke Caucasus Ltd.  
7, Agladze Street  
Tbilisi, 0154 / Georgia  
t: +995 (0)32 2351672  
e: info@franke-ge.com

**ITA**

Franke GmbH  
Oberer Achdamm 52  
6971 Hard / Austria  
t: 800 789233  
e: ws-info.it@franke.com

**NED**

Franke N.V.  
Ring 10  
9400 Ninove / Belgium  
t: +31 (0)492 72 82 24  
e: ws-info.nl@franke.com

**POL**

Franke Aquarotter GmbH  
Parkstrasse 1-5  
14974 Ludwigsfelde / Germany  
t: +48 (0) 22 711 61 17  
e: ws-info.pl@franke.com

**POR**

Franke Portugal S.A.  
Estrada de Talaide, Edifício 3, Cruzamento  
de Sao Marcos, 2735-531 Cacém / Portugal  
t: +351 (0)21 426 9670  
e: ws-info.pt@franke.com

**RSA**

Franke Kitchen Systems (Pty) Ltd.  
1194 South Coast Road  
4060 Moberni / South Africa ZAF  
t: +27 (0)31 450 6300  
e: ws-info.za@franke.com

**RUS**

Franke Neva GmbH  
Volgogradsky prospect, 43 building 3  
109316 Moscow / Russia  
t: +7 495 225 56 58  
e: fs-info.ru@franke.com

**SLO**

Barjans d.o.o.  
Pod Hruševco 20  
1360 Vrhnika / Slovenia  
t: +386 (0)1 750 66 40  
e: info@barjans.si

**SUI**

Franke Washroom Systems AG  
Franke-Strasse 9, Postfach 237  
4663 Aarburg / Switzerland  
t: +41 (0)62 787 3131  
e: ws-info.ch@franke.com

**SVK**

INGEMA s.r.o.  
Močarianska 1  
071 01 Michalovce / Slovakia  
t: +421 (0)56 640 36 12  
e: ingema@ingema.sk

**TUN**

HANDASSA GROUP  
48 Av. Taieb Mhiri Imm. Les Jasmins apt. n°5.  
2080 Ariana / Tunisia  
t: +216 (0)71 702 272  
e: info@handassagroup.com.tn

**TUR**

Franke Mutfak ve Banyo Sistemleri San. ve  
Tic. A.S  
Gebze Organize Sanayi Bölgesi  
Tembelova Alanı 3500 sokak No: 3503  
Gebze, Kocaeli / Türkiye  
t: +90 (0)262 644 6595  
e: ws-info.tr@franke.com

**UAE**

Franke L.L.C  
P.O. Box 14511  
Ras Al Khaimah / United Arab Emirates  
t: +971 (0)7 2034 700  
e: ws-info.ae@franke.com

**USA**

Franke Kindred Canada Limited  
1000 Franke Kindred Road  
Midland, Ontario L4R 4K9 / Canada  
t: +1 855 526 0503  
e: commercial-info.us@franke.com

**Other East-European Countries  
(HU/RO/BG/CRO/SRB/BIH/UKR)**

Franke Aquarotter GmbH  
Parkstrasse 1 - 5  
14974 Ludwigsfelde / Germany  
t: +49 (0)3378 818 0  
e: ws-info.de@franke.com

**Other Countries:**

Franke GmbH  
Oberer Achdamm 52  
6971 Hard / Austria  
t: +43 (0)5574 6735 0  
e: ws-info.int@franke.com