

Montage- und Betriebsanleitung

EN Installation and operating instructions
 ES Instrucciones de montaje y servicio
 CS Návod pro montáž a provoz
 FR Notice de montage et de mise en service

NL Montage- en bedrijfsinstructies
 PL Instrukcja montażu i obsługi
 SV Monterings- och driftinstruktion
 HU Szerelési és használati útmutató
 FI Asennus- ja käyttöohje

EL Συναρμολόγηση και οδηγίες λειτουργίας
 IT Istruzioni per il montaggio e l'uso
 RO Montaj și instrucțiuni de funcționare
 RU Инструкция по монтажу и вводу в эксплуатацию

PRTRS0009

7612982224799

2030025078

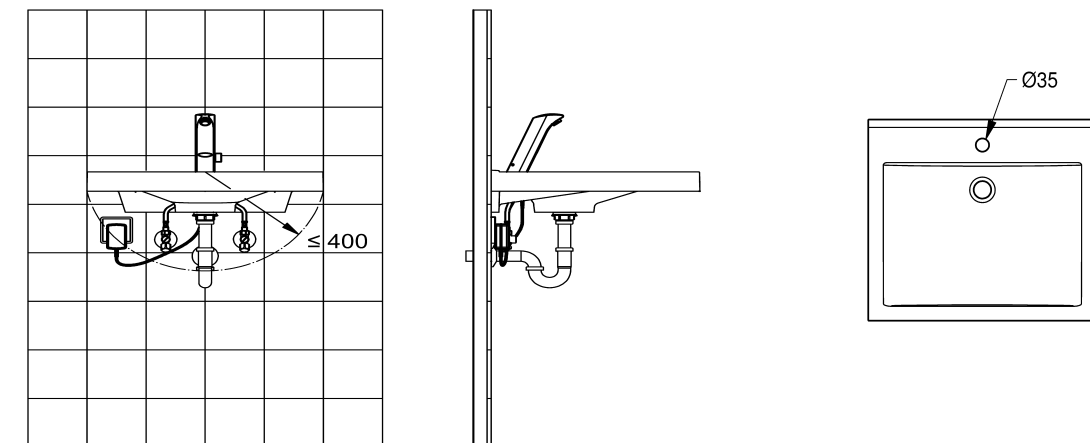
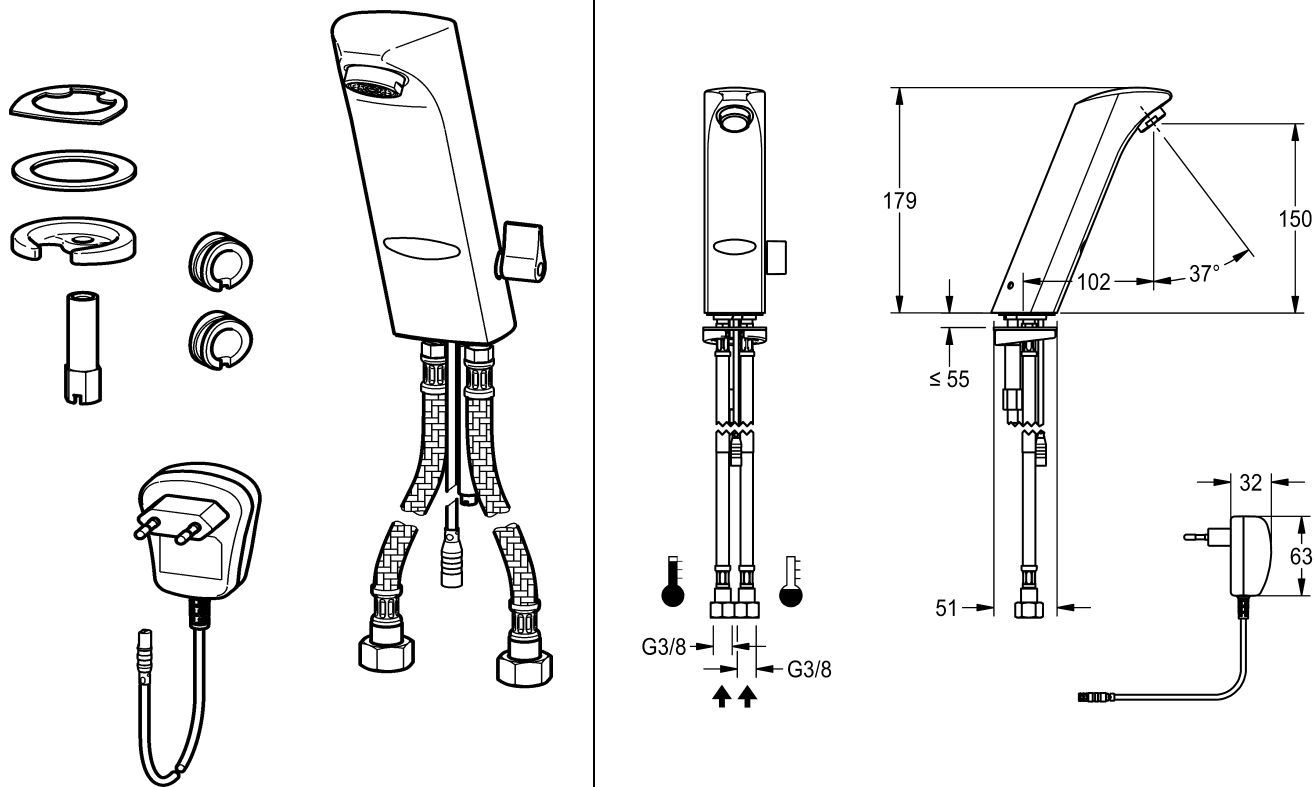

- EN Important notes**
Before installing flush piping system!
After completing the installation, set the temperature limiter!
The fitting must be operated only with original mesh filters and return flow inhibitors!
- FR Remarques importantes**
Rincer les conduites avant d'installer !
Une fois le montage terminé, régler la limitation de température !
Ne faire fonctionner la robinetterie qu'avec les filtres et clapets de non retour d'origine !
- DE Wichtige Hinweise**
Vor Installation Rohrleitungen gemäß DIN 1988 spülen!
Nach erfolgter Montage die Temperaturbegrenzung einstellen!
Armatür nur mit original Sieben und Rückflussverhinderern betreiben!
- ES Indicaciones importantes**
¡Enjuagar las tuberías antes de instalar!
¡Ajuste el límite de temperatura tras realizar el montaje!
¡La grifería debe hacerse funcionar únicamente con los tamices y las válvulas antiretorno originales!
- CS Důležité pokyny**
Před instalací potrubí propláchněte!
Po provedené montáži nastavte omezení teploty!
Provozovat armaturu jen s originálními sítky a zařízeními proti zpětnému toku!
- NL Belangrijke aanwijzingen**
Voor installatie buisleidingen spoelen!
Na de montage de temperatuur-begrenzing instellen!
Armatuur alleen met originele zeven en terugstroomkleppen gebruiken!
- PL Ważne wskazówki**
Przed instalacją przepłukać rury!
Po zakończeniu montażu ustawić ograniczenie temperatury!
Armatury należy używać wyłącznie z oryginalnymi sitkami i zaworami zwrotnymi!
- SV Viktiga informationer**
Spola igenom rörledningarna före installation!
När monteringen har gjorts skall temperaturbegränsningen ställas in!
Använd armaturen endast med originalsilar och originalåterflödesförhindrare!
- HU Fontos utasítások**
Telepítés előtt öblítse át a csővezetékeket!
Összeszerelést követően állítsa be a hőmérséklet-korlátozást!
Az armatúrát kizárólag eredeti szűrőkkel és visszafolyás-gátlókkal üzemeltesse!
- FI Tärkeitä ohjeita**
Huuhtelee putkijohdot ennen asennusta!
Säädä asennuksen jälkeen lämpötilan rajoitus!
Käytä varusteet vain alkuperäisten sihtien ja takaisinvirtauksen eston kanssa!
- EL Σημαντικές οδηγίες**
Πριν από την εγκατάσταση ξεπλύνετε τις σωληνώσεις!
Αφού γίνει η συναρμολόγηση ρυθμίστε το όριο της θερμοκρασίας!
Η μπαταρία να λειτουργεί μόνο με γνήσια κόσκινα και συστήματα ανάσχεσης της αναρροής!
- IT Avvertenze importanti**
Sciacquare le tubazioni prima di installare!
Una volta terminata l'installazione, impostare la limitazione di temperatura!
Utilizzare la rubinetteria esclusivamente con i filtri e le valvole antiriflusso originali!
- RU Важные указания**
Перед инсталляцией промыть трубки!
После монтажа отрегулировать температурный предел!
Эксплуатировать арматуру только с оригинальными фильтрами и клапанами обратного течения!
- RO Indicații importante**
A se spăla conductele de țevi înainte instalatiei!
A se regla limitarea temperaturii după montarea efectuată!
A nu se lua în funcțiune armătura decât cu site originale și cu clapete antiretur!

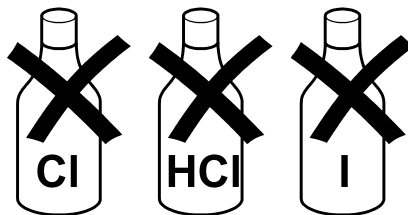
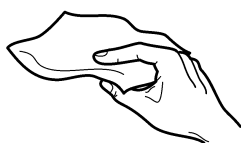
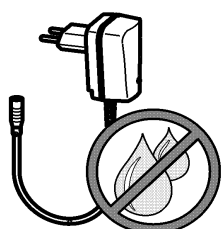

www.franke.com
www.franke.de

EN Technical data		FR Données techniques	
Minimum flow pressure	1,0 bar	Pression dynamique minimale	1,0 bar
Maximum operating pressure	10 bar	Pression de service maximale	10 bars
Recommended flow pressure	3 bar	Pression dynamique recommandée	3 bars
Volume flow	0,10 l/s	Débit volumique	0,10 l/s
Supply voltage	230 V AC	Tension de raccordement	230 V AC
Type of protection	IP 55 / IP 22	Type de protection	IP 55 / IP 22
Operating voltage	6 V DC	Tension de service	6 V DC
DE Technische Daten		ES Datos técnicos	
Mindestfließdruck	1,0 bar	Presión mínima de flujo	1,0 bar
Maximaler Betriebsdruck	10 bar	Presión máxima de servicio	10 bares
Empfohlener Fließdruck	3 bar	Presión de flujo recomendada	3 bares
Volumenstrom bei 3 bar Fließdruck	0,10 l/s	Flujo volumétrico	0,10 l/s
Anschlussspannung	230 V AC	Tensión de conexión	230 V AC
Schutzart	IP 55 / IP 22	Modo de protección	IP 55 / IP 22
Betriebsspannung	6 V DC	Tensión de servicio	6 V CC
NL Technische gegevens		PL Dane techniczne	
Minimale dynamische druk	1,0 bar	Minimalne ciśnienie przepływu	1,0 bar
Maximale werkdruk	10 bar	Maksymalne ciśnienie robocze	10 barów
Aanbevolen dynamische druk	3 bar	Zalecane ciśnienie przepływu	3 barów
Volumestroom	0,10 l/s	Objętościowe natężenie przepływu	0,10 l/s
Aansluitspanning	230 V AC	Napięcie przyłączeniowe	230 V AC
Veiligheidsgraad	IP 55 / IP 22	Rodzaj ochrony	IP 55 / IP 22
Bedrijfsspanning	6 V DC	Napięcie robocz	6 V DC
SV Tekniska data		FI Tekniset tiedot	
Minsta hydrauliska tryck	1,0 bar	Vähimmäisvirtauspaine	1,0 bar
Maximalt drifttryck	10 bar	Suurin käyttöpain	10 bar
Rekommenderat hydrauliskt tryck	3 bar	Suosittelava virtauspaine	3 bar
Volymström	0,10 l/s	Tilavuusvirta	0,10 l/s
Anslutningsspänning	230 V AC	Verkköjännite	230 V AC
Skyddsklass	IP 55 / IP 22	Suojaustapa	IP 55 / IP 22
Driftspänning	6 V DC	Käyttöjännite	6 V DC
IT Specifiche tecniche		RU Технические характеристики	
Pressione idraulica min.	1,0 bar	Минимальный гидравлический напор	1,0 бар
Pressione di esercizio max.	10 bar	Максимальное рабочее давление	10 бар
Pressione idraulica consigliata	3 bar	Рекомендуемый гидравлический напор	3 бар
Portata volumetrica	0,10 l/s	Объемный расход	0,10 л/сек
Tensione di allacciamento	230 V AC	Напряжение питающей сети	230 В переменного тока
Tipo di protezione	IP 55 / IP 22	Вид защиты	IP 55 / IP 22
Tensione di esercizio	6 V DC	рабочее напряжение	6 В постоянного тока
CS Technické údaje		HU Műszaki adatok	
Minimální průtočný tlak	1,0 bar	Minimális áramlási nyomás	1,0 bar
Maximální provozní tlak	10 bar	Maximális üzemi nyomás	10 bar
Doporučený průtočný tlak	3 bar	Javasolt áramlási nyomás	3 bar
Průtok	0,10 l/s	Volumenáram	0,10 l/s
Přípojn	230 V AC	Csatlakozási feszültség	230 V AC
Krytí	IP 55 / IP 22	Védelem típusa	IP 55 / IP 22
Provozní nap	6 V DC	Üzemi feszültség	6 V DC
EL Τεχνικά στοιχεία		RO Datele tehnice	
Ελάχιστη πίεση ροής	1,0 bar	Presiune minimă a curgerii	1,0 bar
Μέγιστη πίεση λειτουργίας	10 bar	Presiune maximă de funcționare	10 bari
Προτεινόμενη πίεση ροής	3 bar	Presiune de curgere recomandată	3 bari
Ρυθμός ογκομετρικής παροχής	0,10 l/s	Fluxul volumic	0,10 l/s
Τάση σύνδεσης	230 V AC	Tensiune de alimentare	230 V AC
Είδος προστασίας	IP 55 / IP 22	Grad de protecție	IP 55 / IP 22
Τάση λειτουργίας	6 V DC	Tensiunea de funcționare	6 V DC

Montage

EN Installation
FR Montage
ES Montaje
CS Montáž

NL Montage
PL Montaż
SV Montering
HU Szerelés
FI Asennus

EL Συναρμολόγηση
IT Montaggio
RU Монтаж
RO Montaj

 13 mm

 19 mm

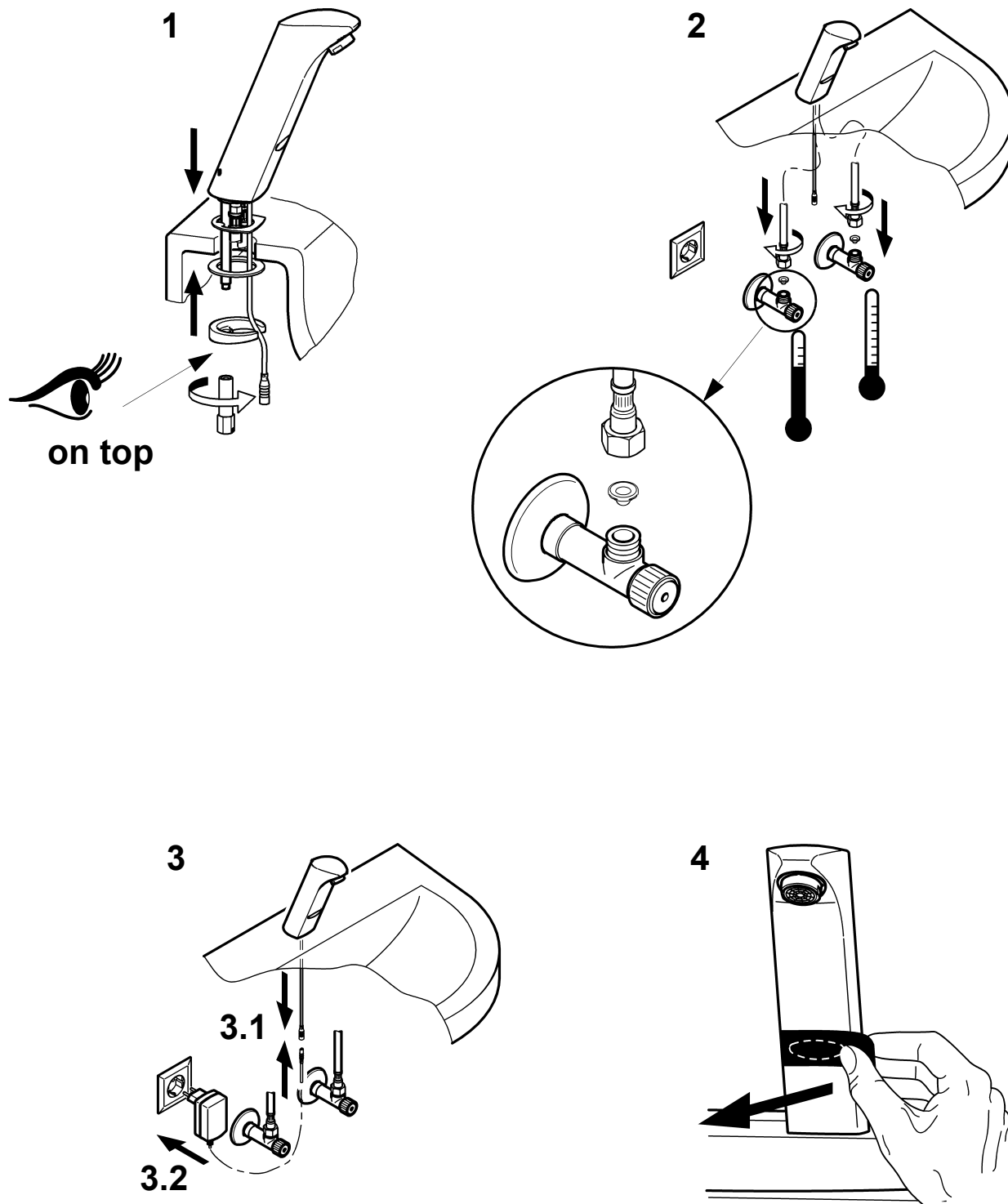

Funktion

EN Function
FR Fonctionnement
ES Función
CS Funkce

NL Werking
PL Funkcja
SV Funktion
HU Funkció
FI Toiminto

EL λειτουργία
IT Funzionamento
RU Функционирование
RO funcție

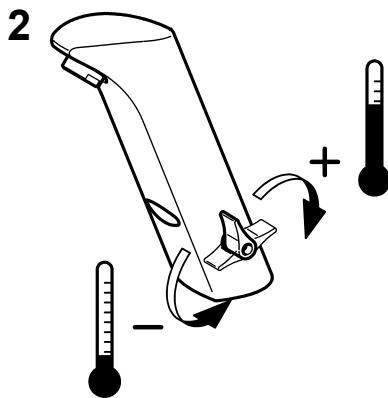
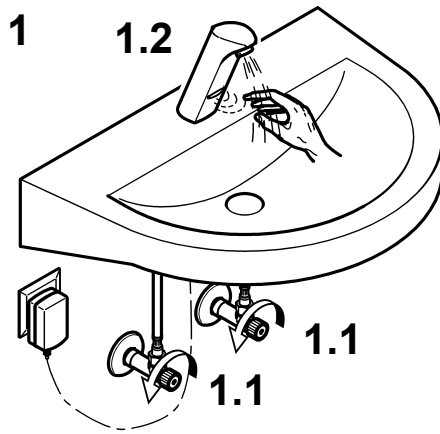

Temperaturbegrenzung einstellen

EN Set the temperature limiter

FR Régler la limitation de température

ES Ajuste el límite de temperatura

CS Nastavit omezení teploty

NL Temperatuurbegrenzing instellen

PL Ustawić ograniczenie temperatury

SV Ställ in temperaturbegränsningen

HU Hőmérsékletkorlátozás beállítása

FI Säädä lämpötilan rajoitus

EL Ρύθμιση ορίου θερμοκρασίας

IT Impostare la limitazione di temperatura

RU установить ограничение по температуре

RO A se regla limitarea temperaturii

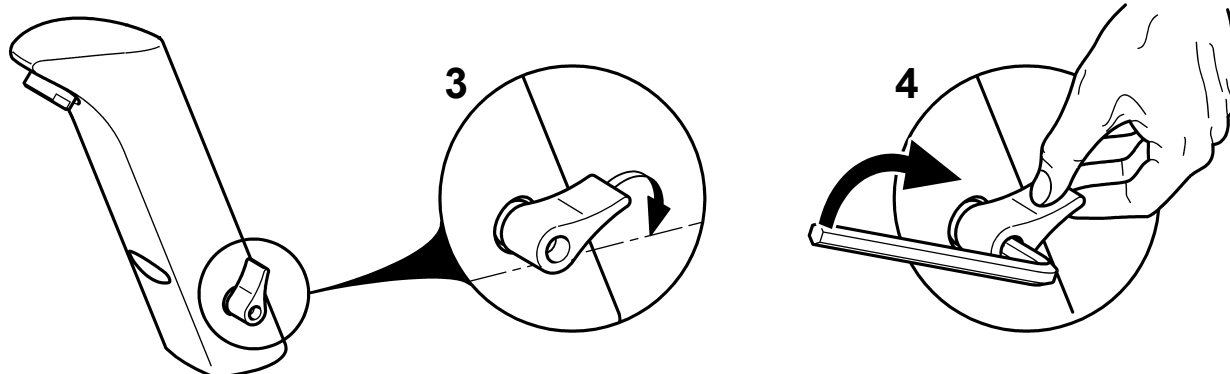
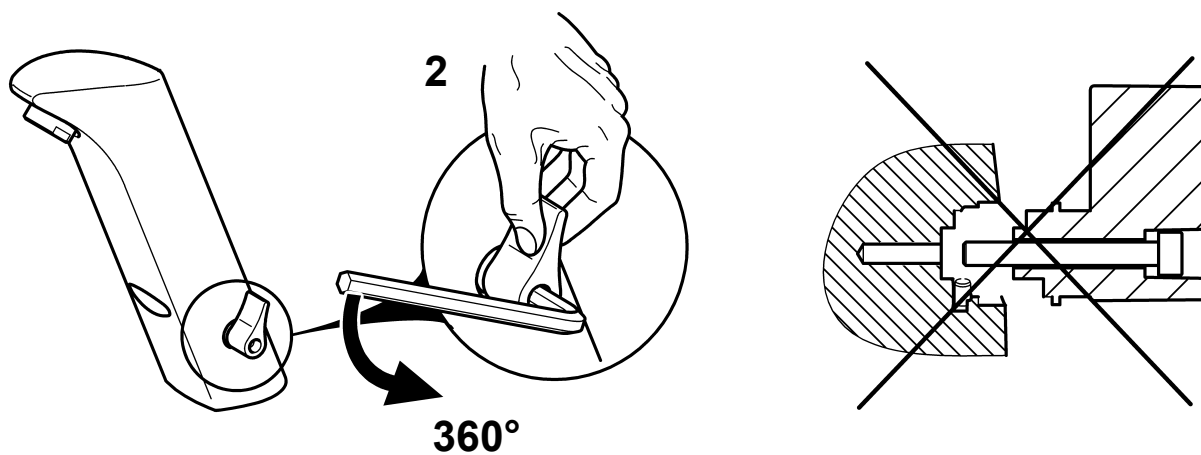
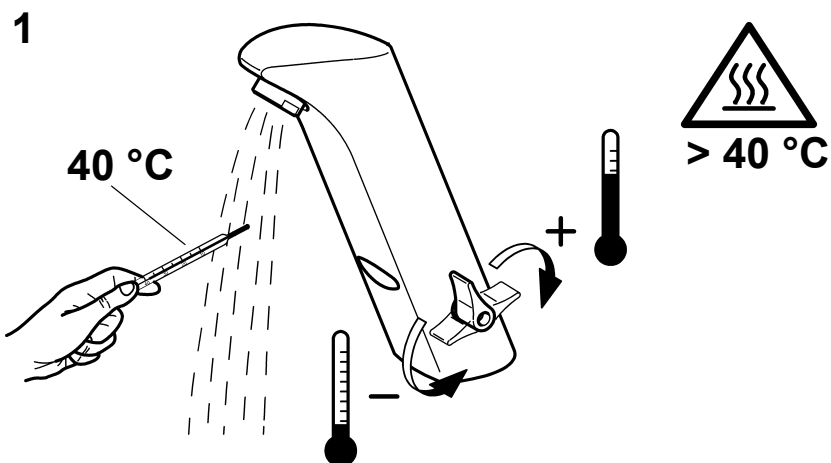
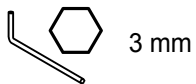

Anzeige: letzter Spülvorgang in Stunden

EN Display: Last flush-process in hours	NL Weergave: laatste spoelprocedure in uren	EL Ένδειξη: τελευταία διαδικασία πλύσης σε ώρες
FR Affichage: dernière opération de rinçage en heures	PL Informacja: ostatnie splukiwanie w godzinach	IT Indicazione: ultimo sciacquo in ore
ES Indicación: último proceso de aclarado en hora	SV ndikering: Sista sköljning i timmar	RU На дисплее: последний смывной процесс в часах
CS Upozornění: poslední vypláchnutí v hodinách	HU Értésítés: az utolsó öblítési folyamat órában megadva	RO Afişaj: ultimul proces de spălare, exprimat în ore
	FI Näyttö: viimeisin huuhtelutapahtuma tunteina	

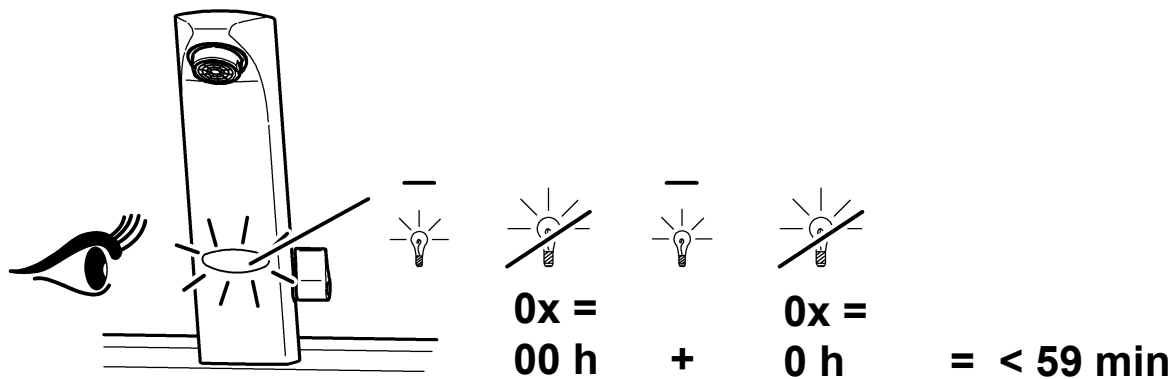
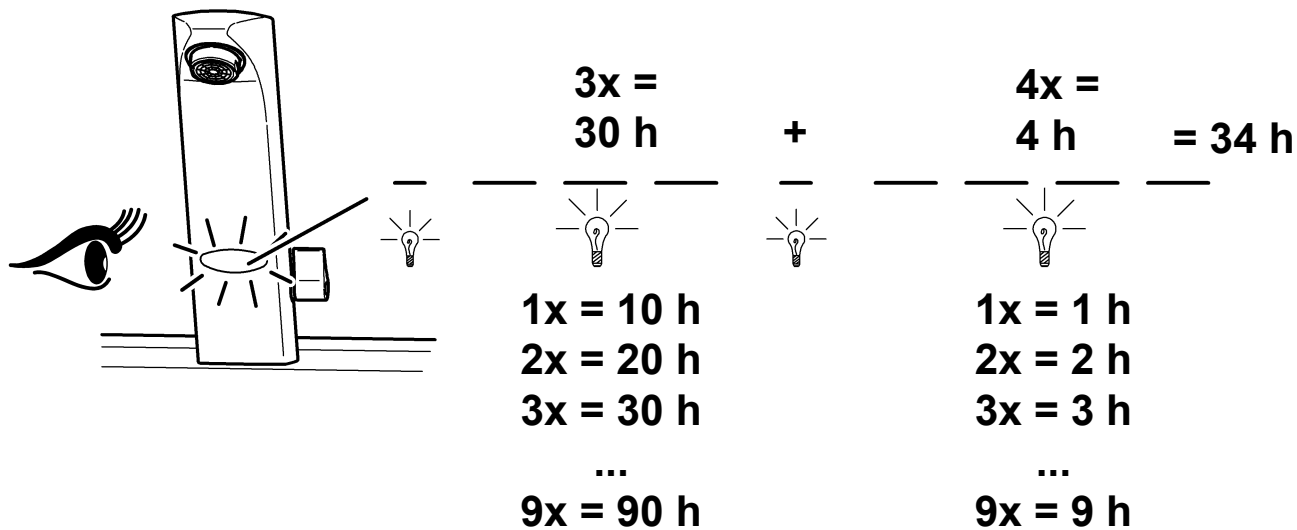
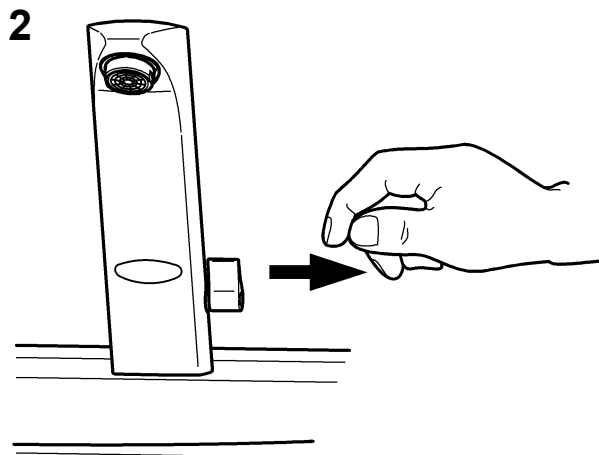
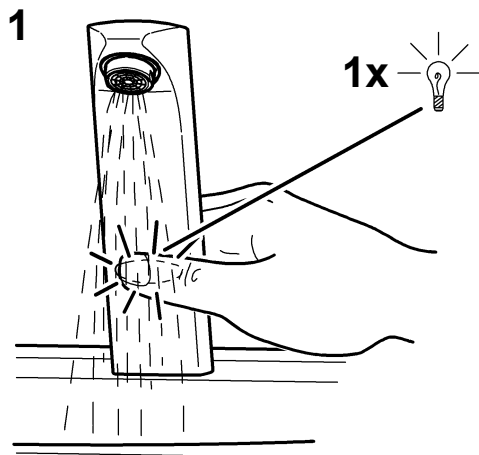

Anzeige: Status Hygienespülung

EN Display: Status hygiene flushing

FR Affichage : état rinçage hygiénique

ES Indicación: estado del enjuague de higiene

CS Indikátor: stav hygienického omytí

NL Aanduiding: Status hygiënespoeling

PL Wyświetlacz: status splukiwania higienicznego

SV Indikering: Status hygiensköljning

HU Kijelző: Higiéniai öblítés állapot

FI Näyttö: hygieniahuhtelun tilanne

EL Ένδειξη: Κατάσταση υγιεινής πλύσης

IT Indicazione: stato sciacquo igienico

RU Индикатор: состояние гигиенической мойки

RO Indicator: statut de spălat igienic

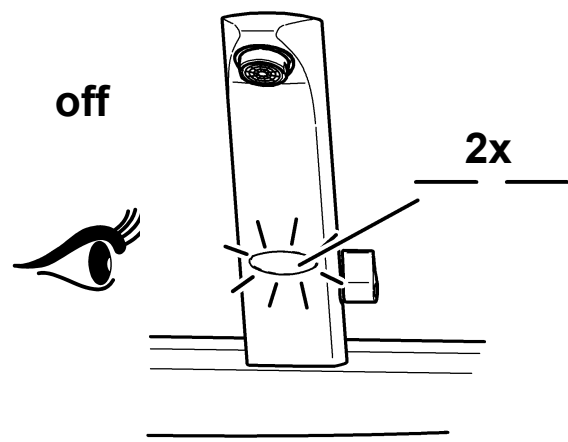
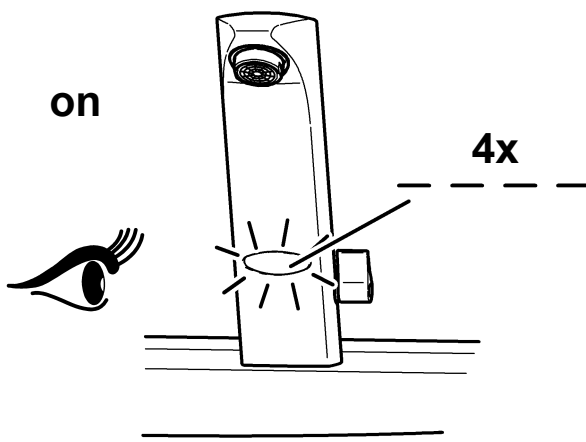
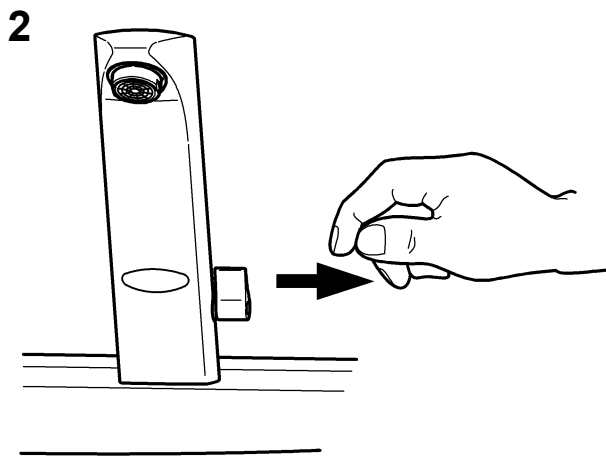
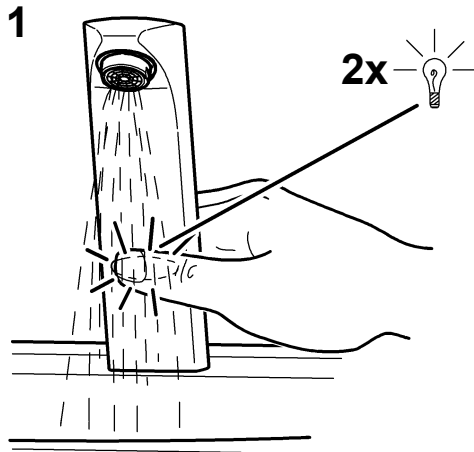

Armatur ausschalten

EN Switch off the valve
 FR Désactiver la robinetterie
 ES Desconectar la grifería
 CS Vypnout armaturu

NL Armatuur uitschakelen
 PL Wyłączenie baterii
 SV Avstängning av armatur
 HU Armatúra kikapcsolása
 FI Laitteen kytkeminen pois päältä

EL Απενεργοποίηση μπαταρίας
 IT Disattivazione della rubinetteria
 RU отключить оборудование
 RO A se opri armătura

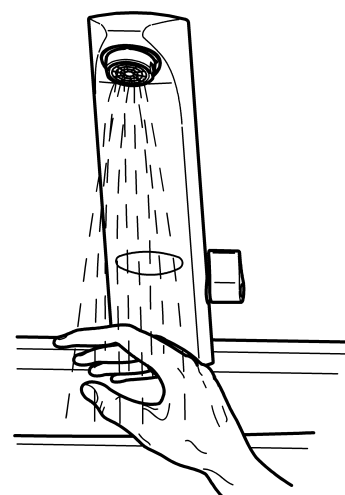
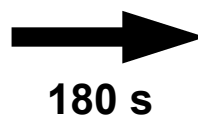
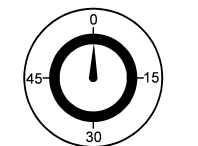
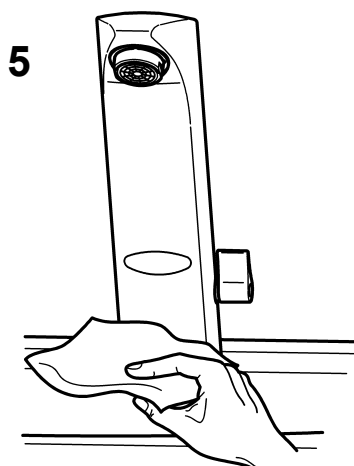
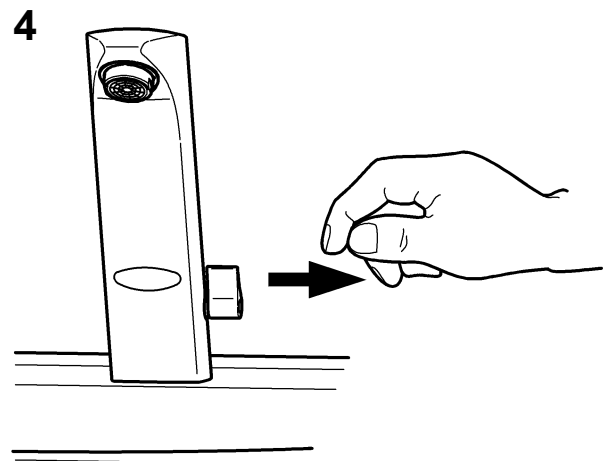
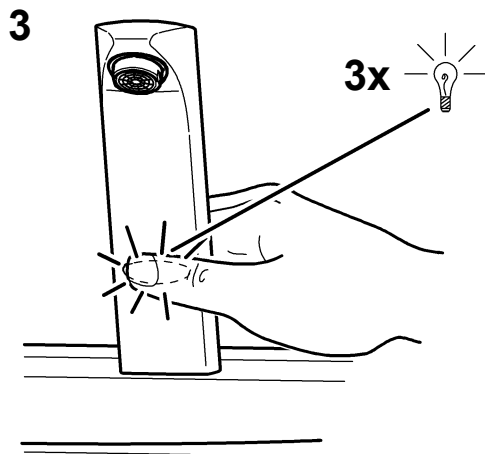
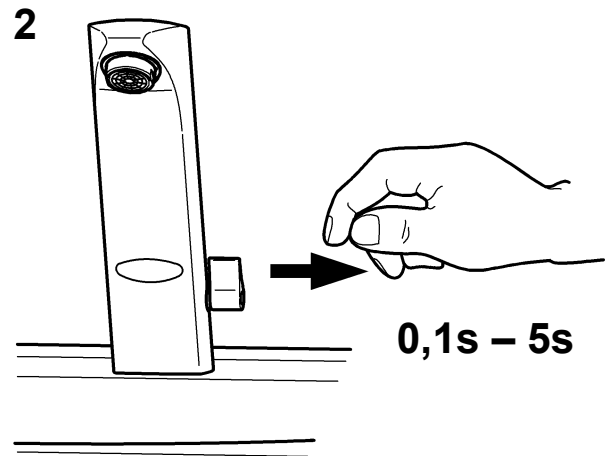
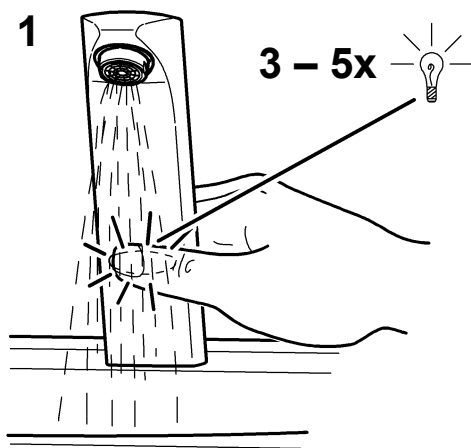

Dauerlauf starten

EN Start continual flow
 FR Démarrer la marche continue
 ES Iniciar el enjuague continuo
 CS Spustit trvalý provoz

NL Continue stroming starten
 PL Uruchomić stały wypływ wody
 SV Starta kontinuerlig drift
 HU Folyamatos futás indítása
 FI Tuotantokäytön aloittaminen

EL Εκκίνηση διαρκούς ροής
 IT Avviare l'erogazione continua
 RU запустить ресурс
 RO A se porni rularea permanentă

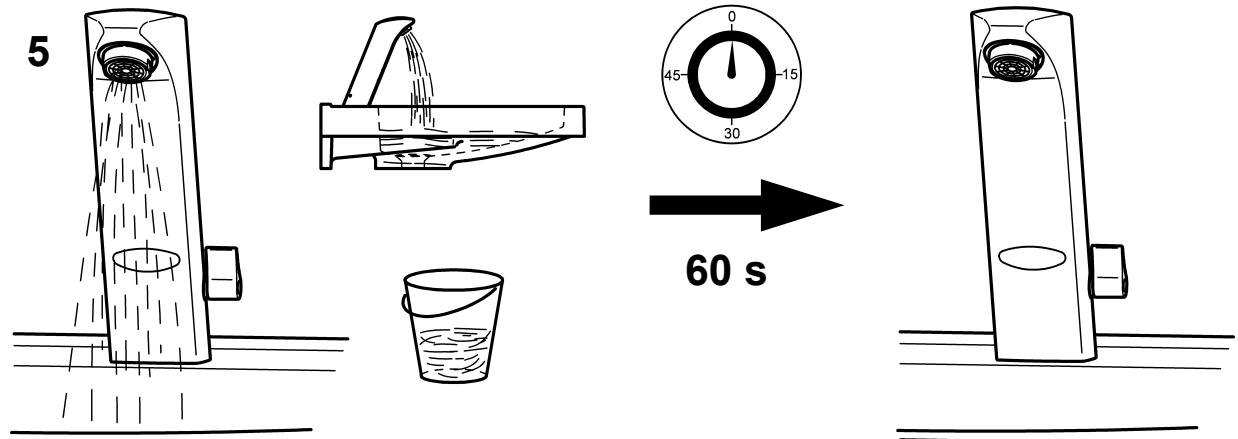
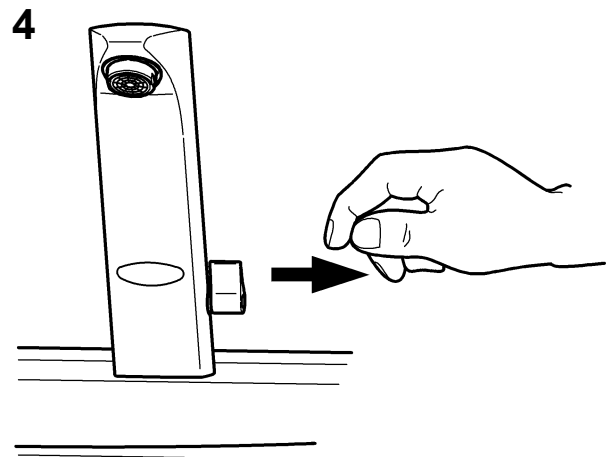
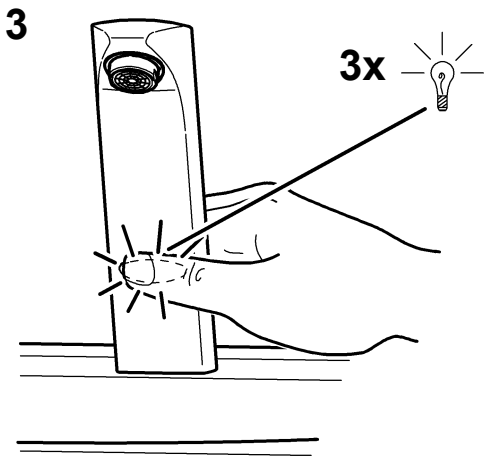
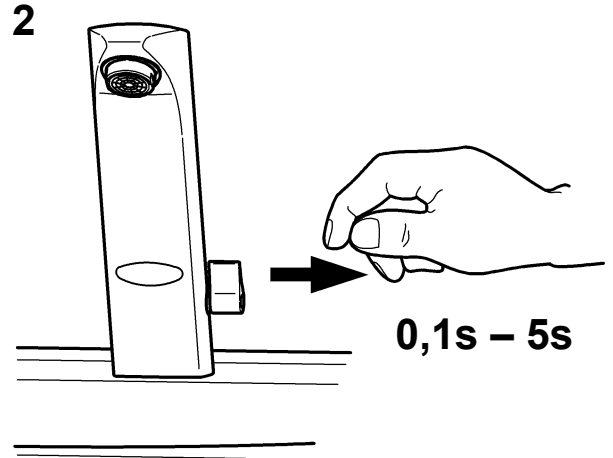
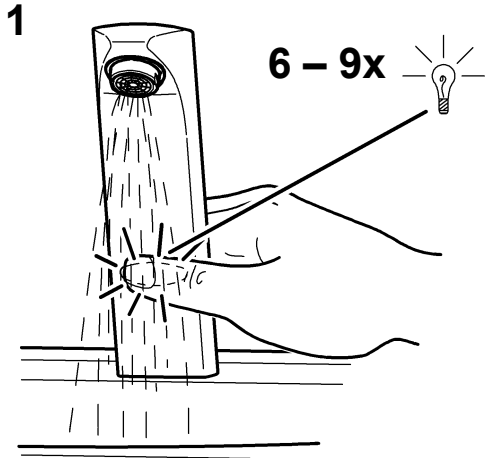

Hygienespülung ein- / ausschalten

EN Switching hygiene flushing on/off	NL Hygiënische spoeling in-/uitschakelen	EL Ενεργοποίηση/απενεργοποίηση υγιεινής πλύσης
FR Activer/désactiver le rinçage hygiénique	PL Włączyć/wyłączyć splukiwanie higieniczne	IT Attivare/disattivare lo sciacquo igienico
ES Activar/Desactivar el aclarado higiénico	SV Koppla hygienspolningen till / från	RU Гигиеническое промывание включить/выключить
CS Zapnĕte/vypnĕte hygienické propláchnutí	HU Higiénias öblítés be-/ ki-kapcsolása	RO Pornit/oprit clătire igienica
	FI HygieniahuuhTELun päälle-/ pois päältä kytkeminen	

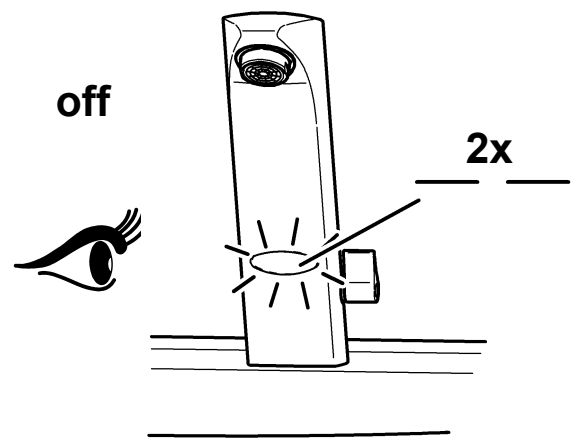
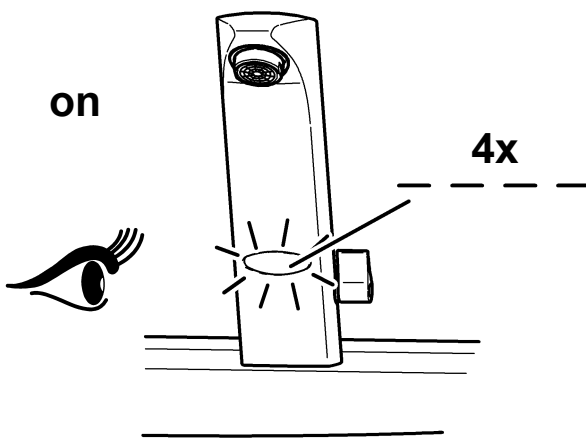
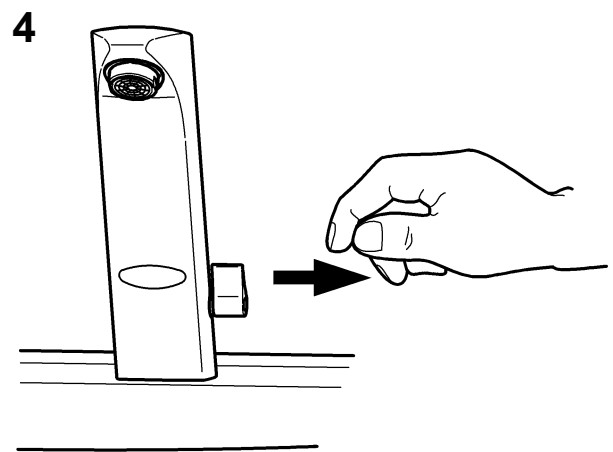
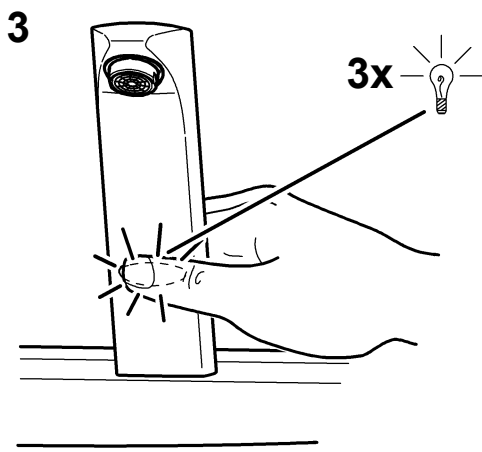
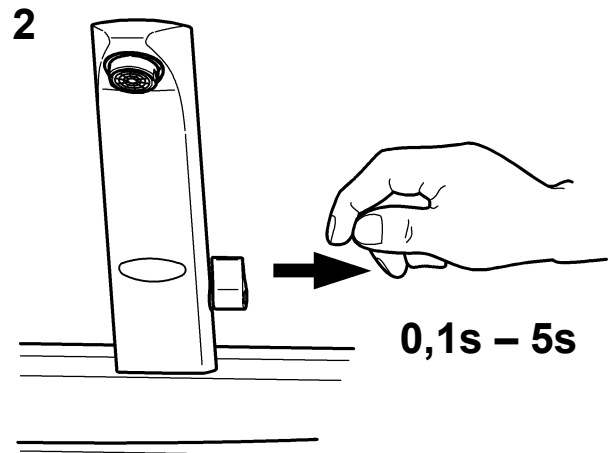
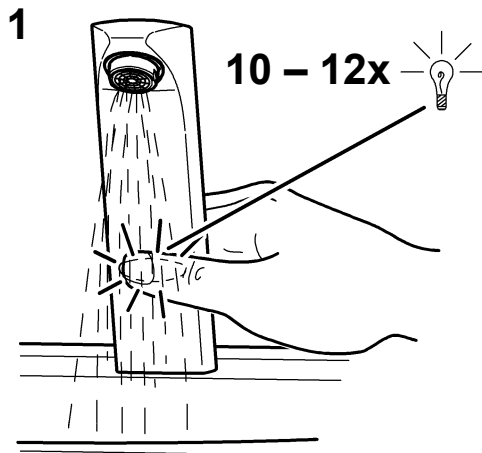

EN Ensure open outlet. After 24h of non-use, water flows 10 sec.	NL Vrije uitloop garanderen. Na 24 uur niet te zijn gebruikt stroomt er gedurende 10 sec. water.	EL Εξασφαλίστε ανεμπόδιστη εκροή. Εάν δεν χρησιμοποιηθεί επί 24 ώρες, θα ρεύσει νερό επί 10 δευτερόλεπτα.
FR Garantir un écoulement libre. L'eau s'écoule pendant 10 sec. après 24h de non utilisation.	PL Zapewnić swobodny wylot. Po 24 godz. niekorzystania przez 10 s. wypływa woda.	IT Garantire l'erogazione libera. Dopo 24h di inutilizzo scorre acqua per 10 sec.
DE Freien Auslauf gewährleisten. Nach 24h Nichtbenutzung fließt 10 sec Wasser.	SV Garantera fritt avlopp. Vatten flyter 10 sek efter 24 timmars användningspaus.	RU Обеспечить беспрепятственный слив После того, как устройство не используется в течение 24 ч, в течение 10 сек течёт вода.
ES Garantizar una salida libre. Si no se realiza ningún uso durante 24 horas, fluye agua durante 10 segundos.	HU Szabad kifolyás biztosítása. Minden használat nélkül eltelt 24 ó után 10 mp-ig folyik a víz.	RO A se asigura o scurgere libera. Daca nu se foloseste timp de 24 ore, a se lasa apa sa se scurga timp de 10 s.
CS Zajistěte volný odtok. Při nepoužívání 24 h nechte 10 s téct vodu.	FI Vapaa virtauksen takaaminen. Käyttämättömänä 24 h jälkeen virtaa vettä 10 s	

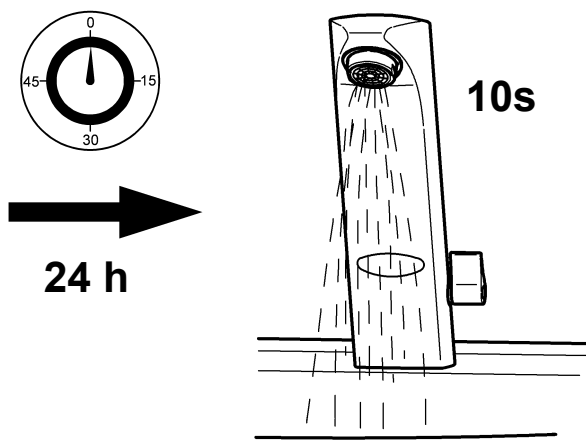

Erfassungsart ändern

EN Change type of detection
FR Modifier le type de détection
ES Modificar el tipo de captación
CS Změnit způsob snímání

NL Registratiesoort wijzigen
PL Zmiana rodzaju wykrywania
SV Registreringssätt
HU Érzékelés módja
FI Mittaustyyppin muuttaminen

EL Αλλαγή τρόπου ανίχνευσης
IT Modificare il tipo di rilevamento
RU Способ считывания
RO Modificare mod de scanare

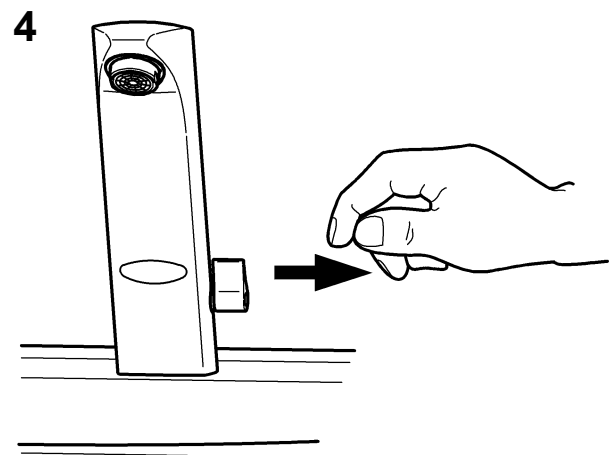
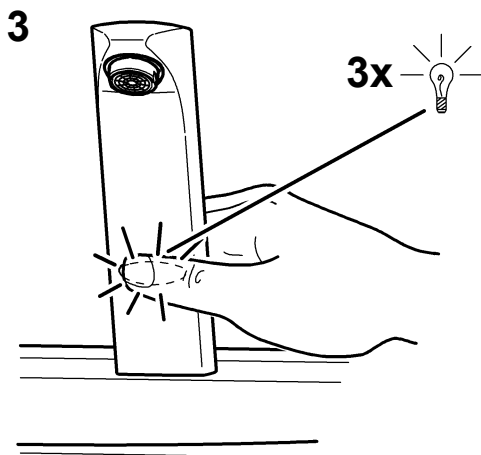
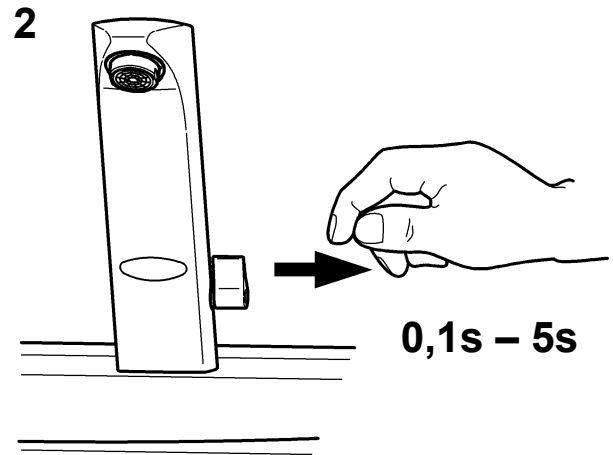
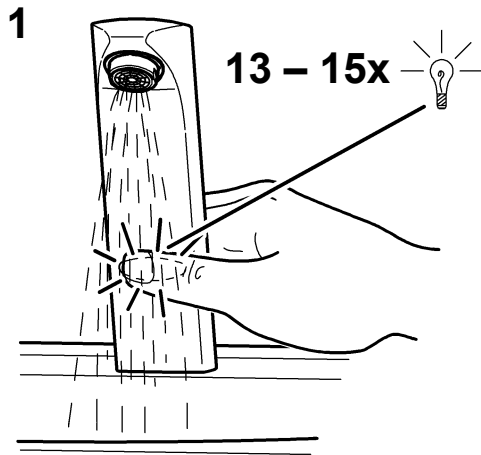

EN	Type of detection	The sensor is detecting
A	static	Object
B	dynamic	Movement (with intense reflections from basin)

FR	Type de détection	Le capteur détecte
A	statique	Objet
B	dynamique	Mouvement par forte réflexion du bassin

DE	Erfassungsart	Der Sensor erfasst
A	statisch	Objekt
B	dynamisch	Bewegung (bei hoher Beckenreflexion)

ES	Tipo de captación	El sensor está captando
A	estático	Objeto
B	dinámico	Movimiento (en caso de elevada reflexión en el lavabo)

NL	Registratiesoort	De sensor registreert
A	statisch	Object
B	dynamisch	Beweging (bij hogere reservoirreflectie)

PL	Rodzaj wykrywania	Czujnik rejestruje
A	statisch	Obiekt
B	dynamisch	Ruch (przy dużym odbiciu fali od umywalki)

SV	Registreringsätt	Sensor registrerar
A	statisk	Objekt
B	dynamisk	Rörelse (vid hög bäckenreflexion)

FI	Mittautyyppi	Anturi mittaa
A	staattinen	Kohde
B	dynaminen	Liike (suurella allasheijastuksella)

IT	Tipo di rilevamento	Il sensore rileva
A	statico	Oggetto
B	dinamico	Movimento (in caso di alta riflessione del lavabo)

RU	Способ считывания	Датчик считывает
A	статический	Объект
B	динамический	Движение (при большом отражении умывальника)

CS	Způsob snímání	Snímač snímá
A	statický	Objekt
B	dynamický	Pohyb (při vysokém odrazu umyvadla)

HU	Érzékelés módja	A szenzor érzékel
A	statikus	Tárgy
B	dinamikus	Mozgás (erős medence-visszaverődés esetén)

EL	Τρόπος ανίχνευσης	Ο αισθητήρας ανιχνεύει
A	στατικός	Αντικείμενο
B	δυναμικός	Κίνηση (με νιπτήρες υψηλής ανακλαστικότητα)

RO	Mod de scanare	Senzorul scanează
A	static	Obiect
B	dinamic	Mișcare (când reflexia chiuvetei este mare)

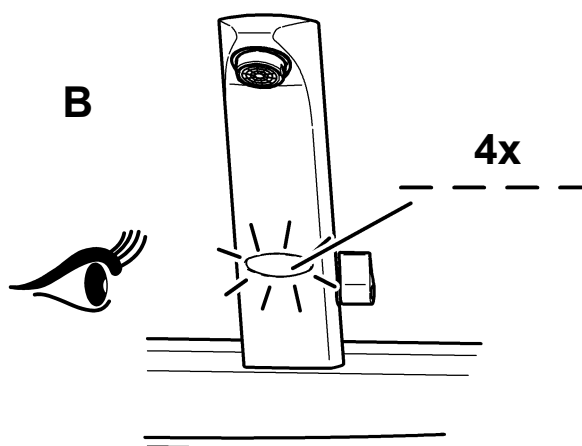
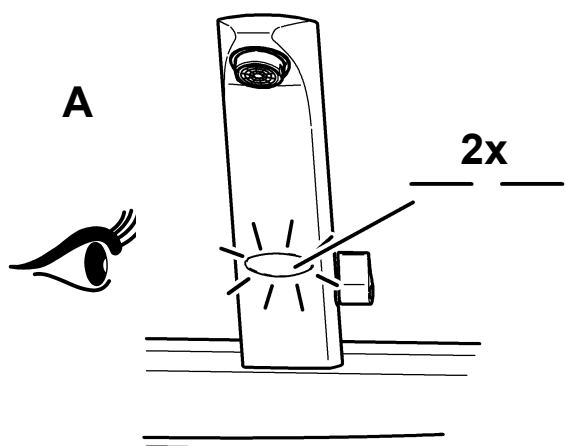

Wartung

EN Maintenance
FR Maintenance
ES Mantenimiento
CS Varování

NL Onderhoud
PL Konserwacja
SV Underhill
HU Figyelmeztetés
FI Huolto

EL Προειδοποίηση
IT Manutenzione
RU Техническое обслуживание
RO Avertisment

 19 mm

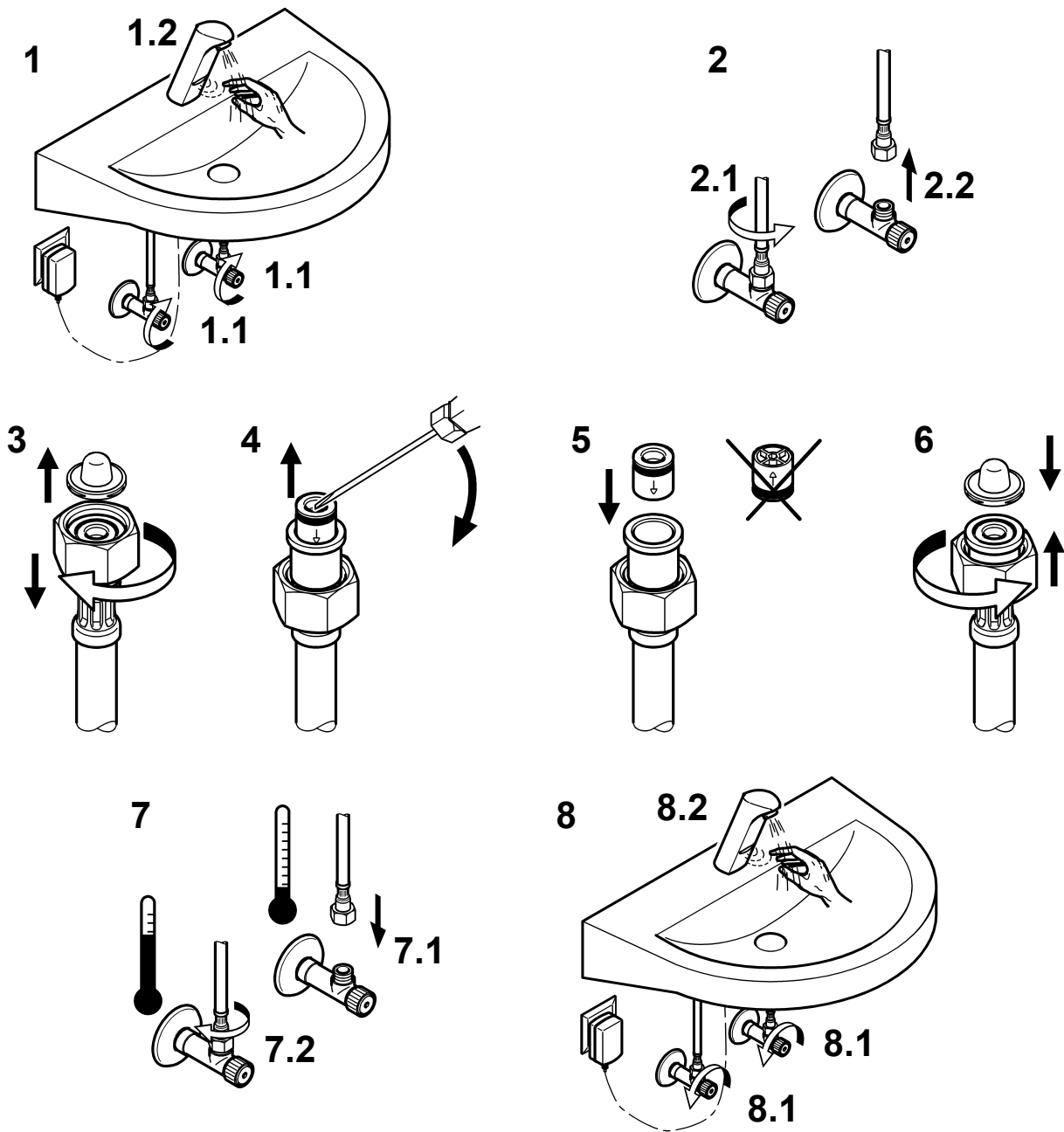

 22 mm

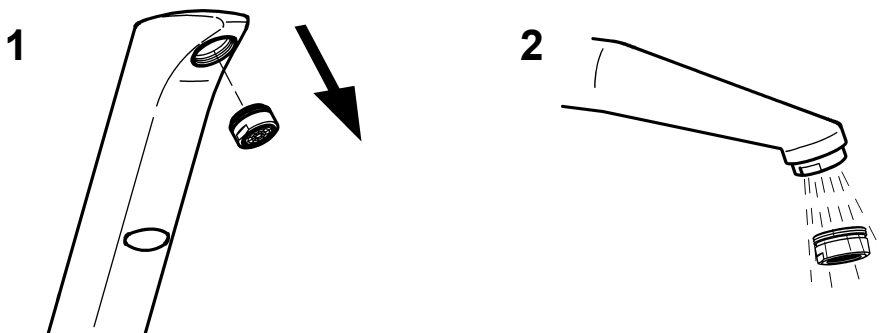

ZMI_001_2030025078-PRTRS0009_#SALL_#AQU_#V1_fm

Funktionsteil ausbauen

EN Remove functional part
 FR Démontér l'élément fonctionnel
 ES Desmontar la pieza funcional
 CS Demontovat funkční díl

NL Functie-element demonteren
 PL Wymontować element funkcjonalny
 SV Bygga ut funktionsdelen
 HU Funkcionális elem kiszerelése
 FI Kunnossapito

EL Αφαίρεση τμήματος λειτουργίας
 IT Smontaggio dell'elemento funzionale
 RU Демонтаж функциональной детали
 RO A se demonta piesa funcțională

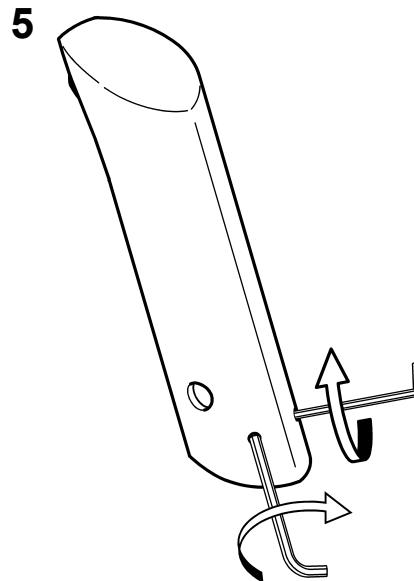
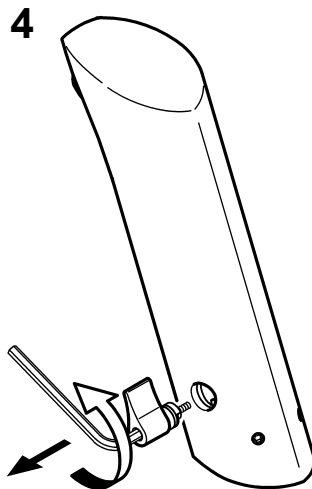
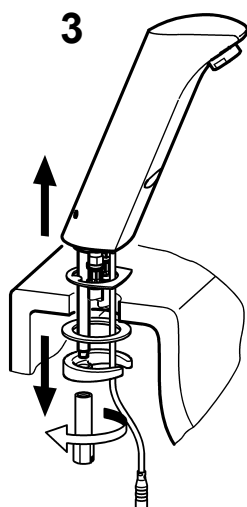
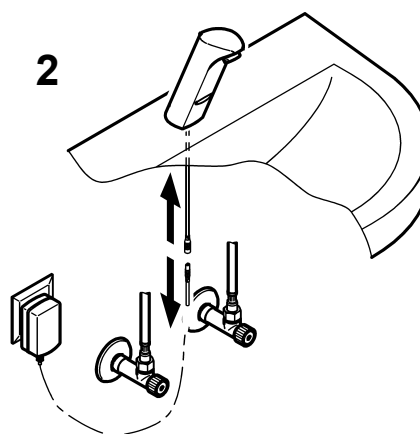
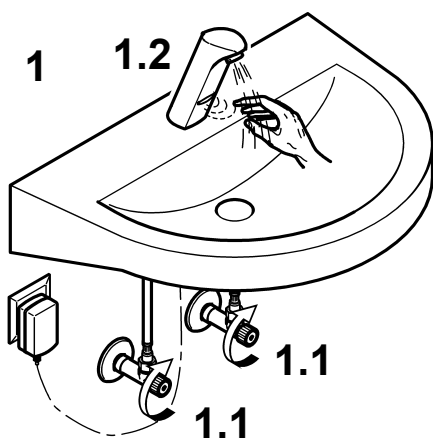
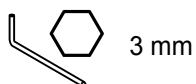

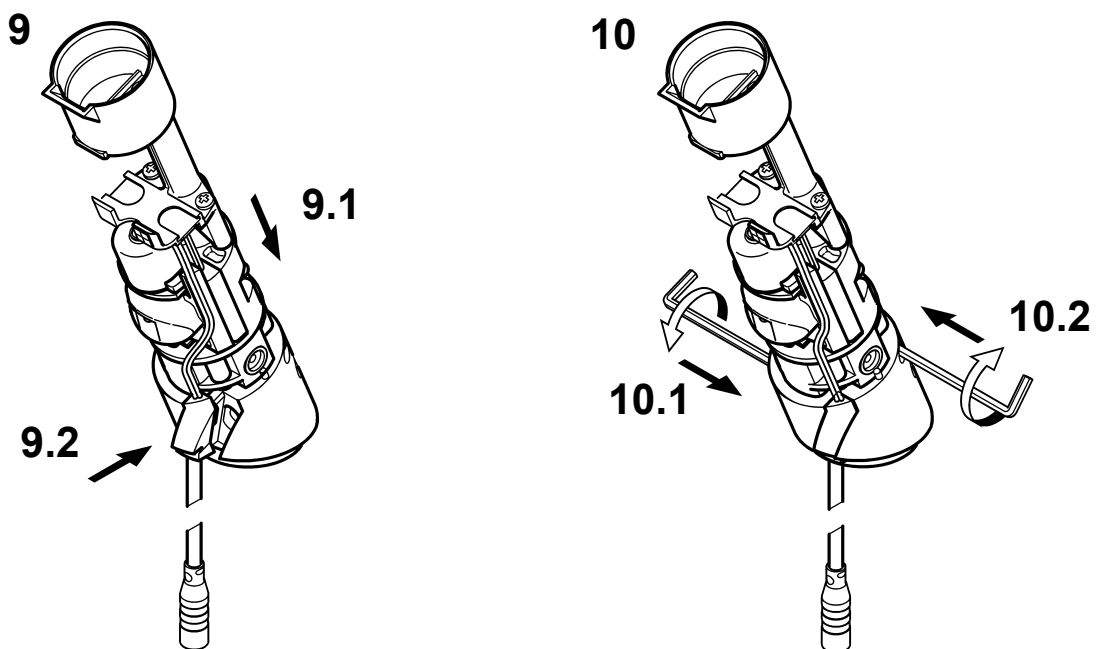
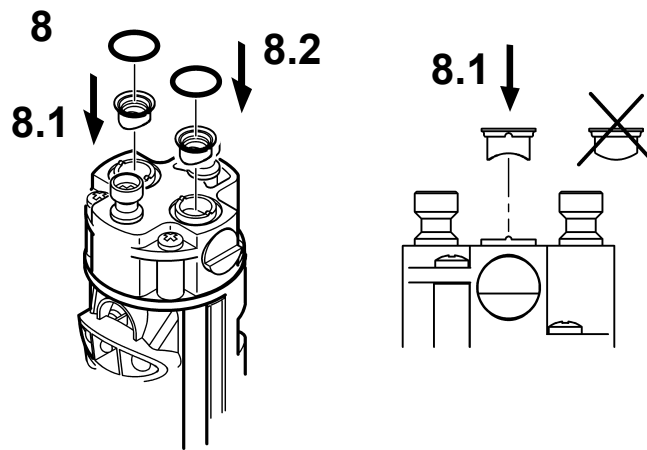
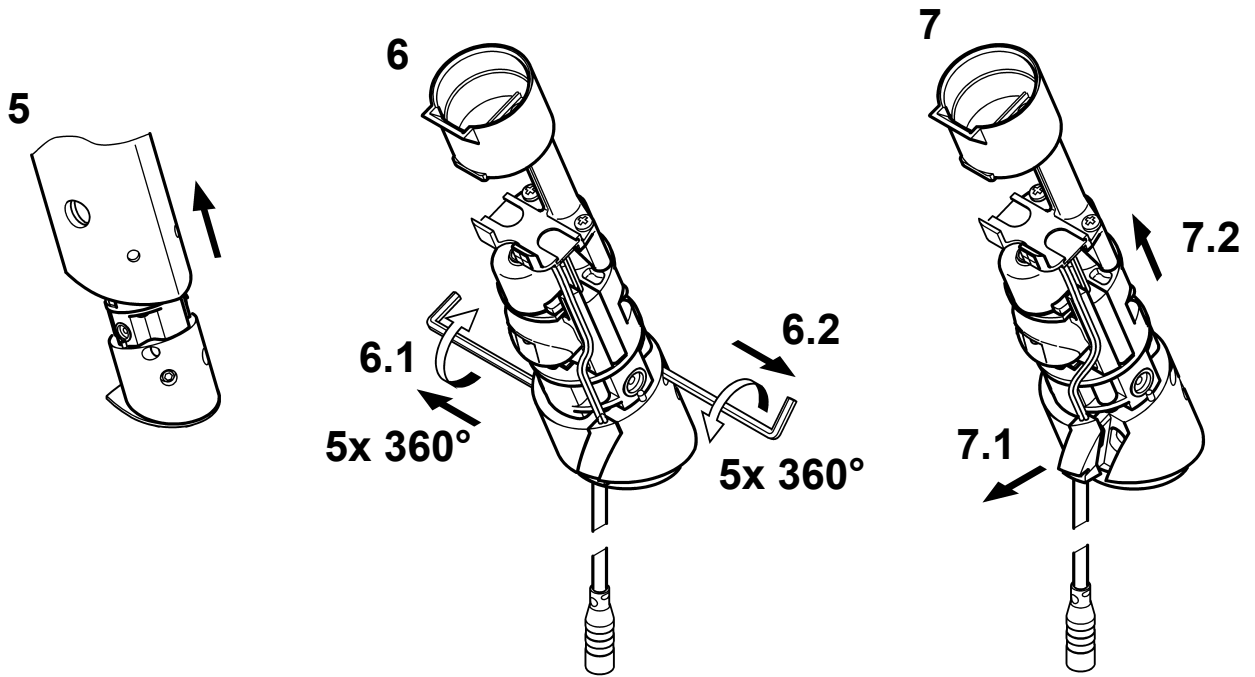

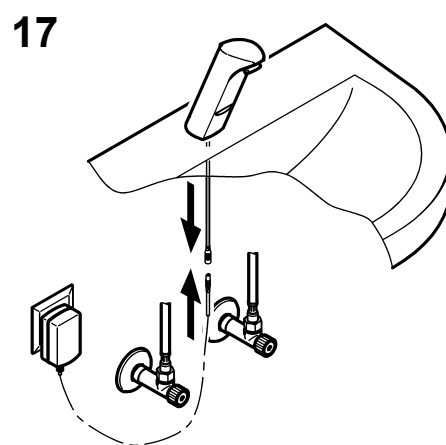
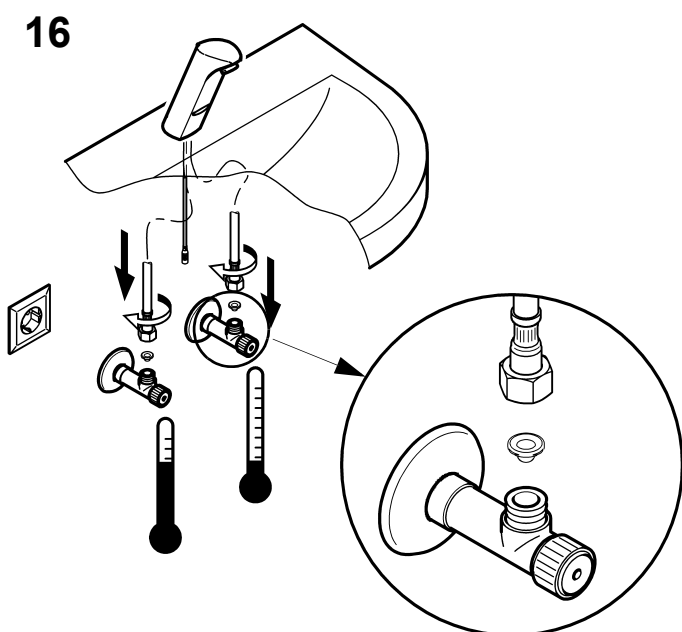
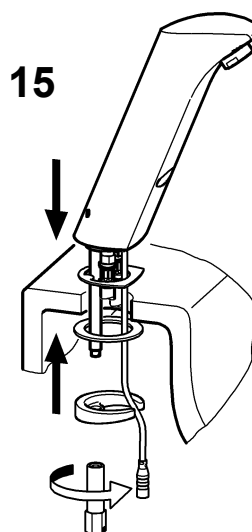
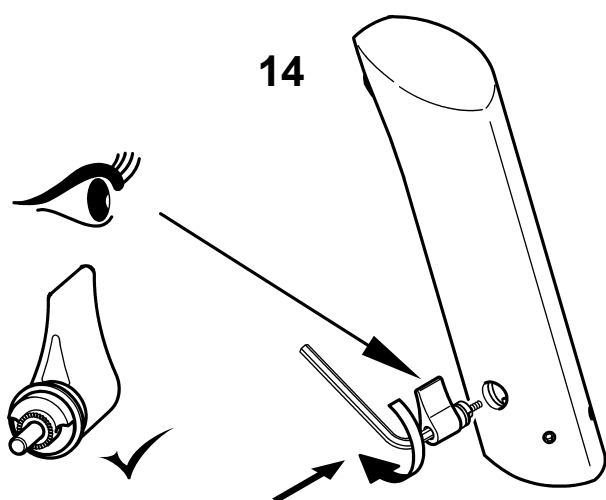
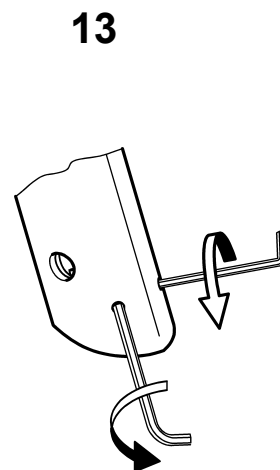
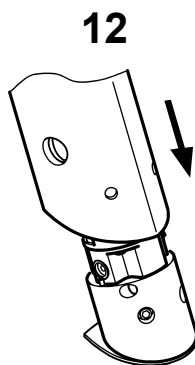
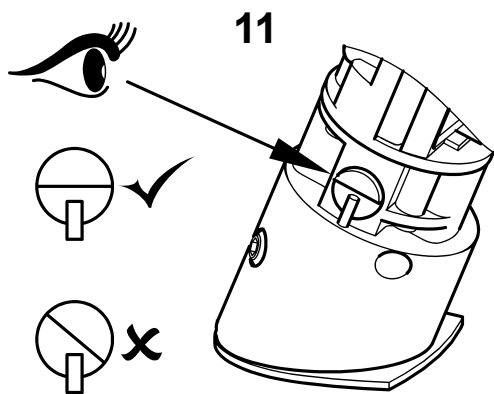

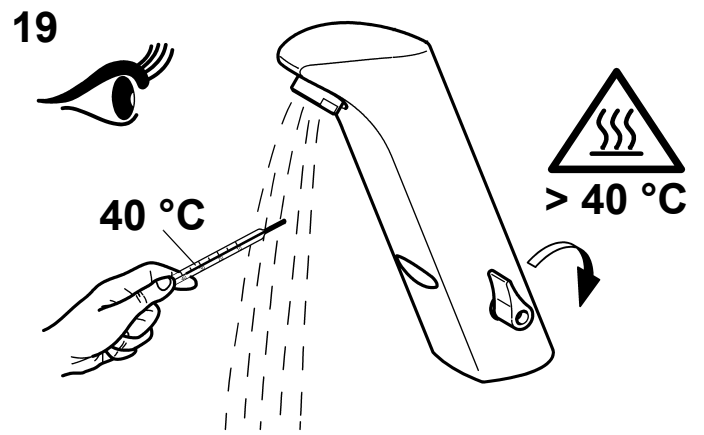
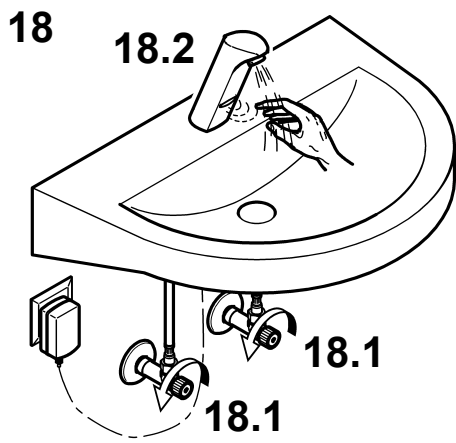

Mischeinrichtung verdecken

EN Conceal mixed-water facility
 FR Dispositif mélangeur
 ES Cubrir el elemento mezclador
 CS Zakrýt míchací zařízení

NL Menginrichting verbergen
 PL Zakryć urządzenie mieszające
 SV Dölj blandingsanordning
 HU Fedje le a keverőberendezést
 FI Peittää miksauslaitte

EL Κάλυψη συστήματος ανάμειξης
 IT Coprire il blocco di miscelazione
 RU Закрыць смеситель так, чтобы его не было видно
 RO A se acoperi etajul de amestec

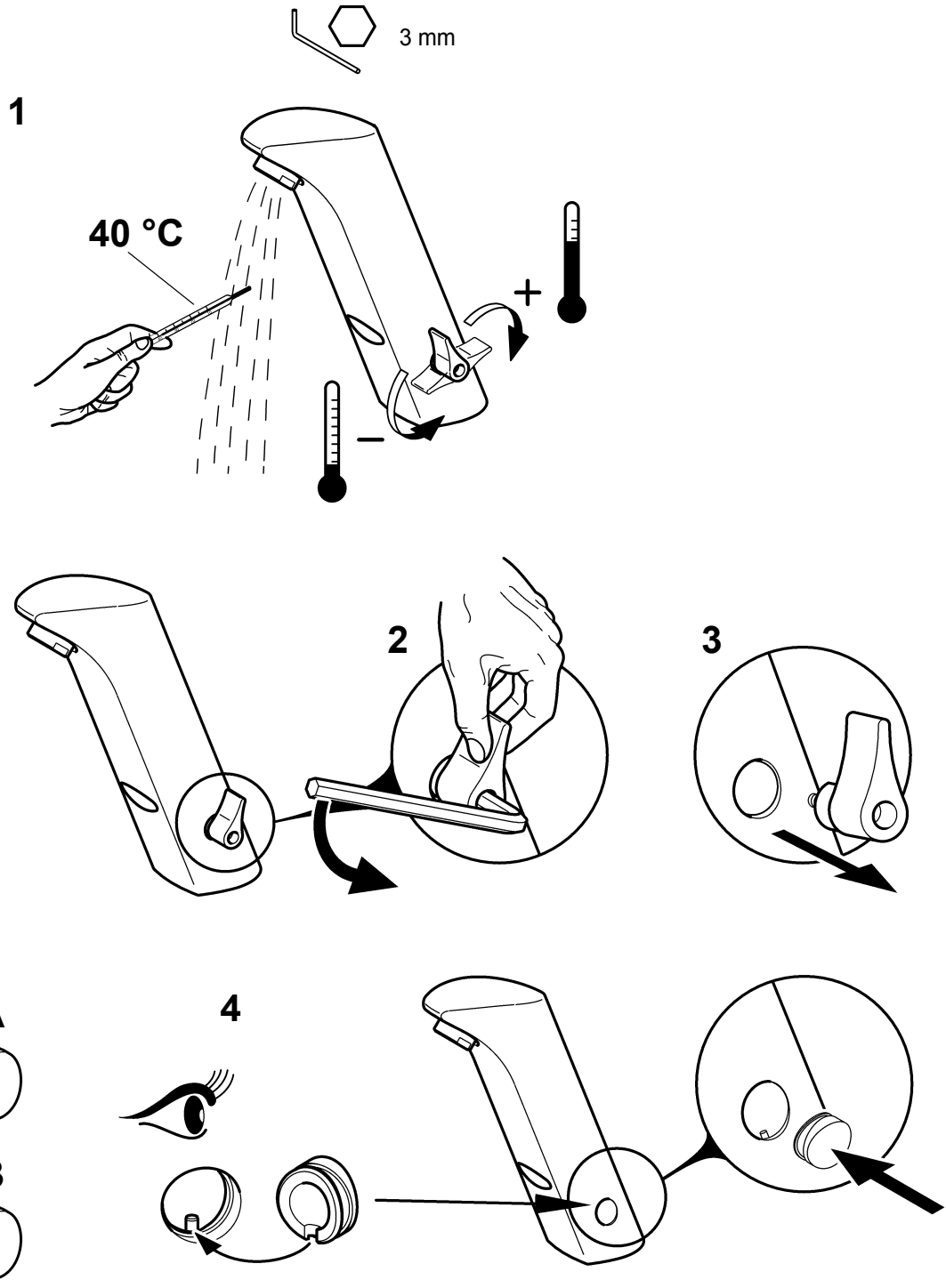

EN A Red
 B Blue

FR A Rouge
 B Bleu

DE A Rot
 B Blau

ES A Rojo
 B Azul

CS A Červený
 B Modrý

NL A Rood
 B Blauw

PL A Czerwony
 B Niebieski

SV A Röd
 B Blå

HU A Piros
 B Kék

FI A Punainen
 B Sininen

EL A Κόκκινο
 B Μπλε

IT A Rosso
 B Blu

RU A красный
 B голубой

RO A Roșu
 B Albastru

Ersatzteile

EN Replacement parts
FR Pièces de rechange
ES Piezas de recambio
CS Náhradní díly

NL Reserveonderdelen
PL Części zamienne
SV Reservdelar
HU Pótalkatrészek
FI Varaosat

EL Ανταλλακτικά
IT Pezzi di ricambio
RU Запчасти
RO Piese de schimb

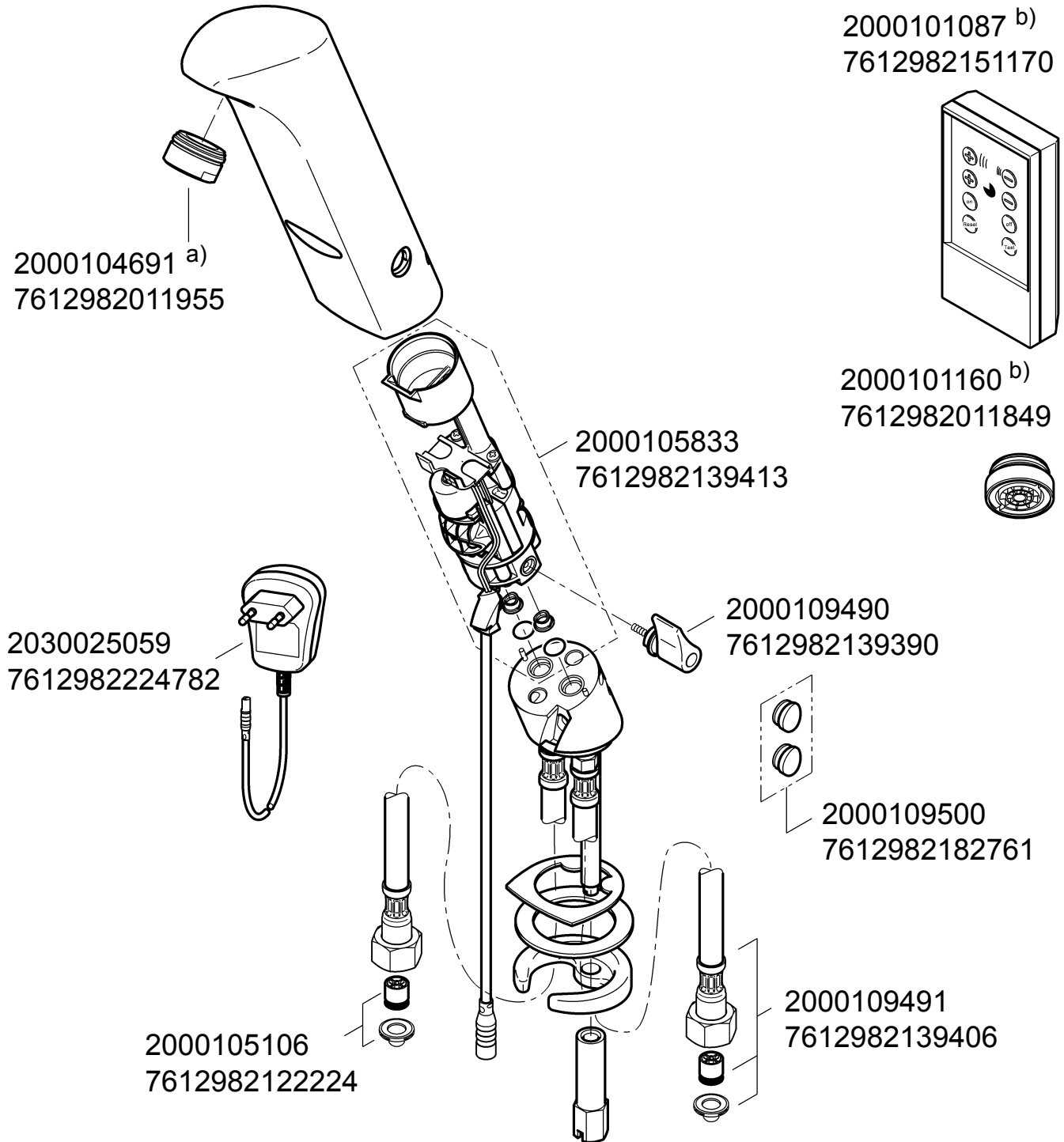

EN a) 10 pieces
b) Accessories

FR a) 10 pièces
b) Accessoires

DE a) 10 Stück
b) Zubehör

ES a) 10 piezas
b) Accesorios

CS a) 10 kusů
b) Příslušenství

NL a) 10 stuk
b) Toebehoren

PL a) 10 sztuk
b) Akcesoria

SV a) 10 styck
b) Tillbehör

HU a) 10 darab
b) Alkatrész

FI a) 10 kappaletta
b) Varusteet

EL a) 10 τεμάχια
b) Αξεσουάρ

IT a) 10 pezzi
b) Accessori

RU a) 10 штук
b) принадлежности

RO a) 10 bucăți
b) Accesorii

ZMI_001_2030025078-PRTRS0009_#SALL_#AQU_#V1_fm

WELL Public

Water Efficiency Label

Hersteller: Franke Aquarotter GmbH
Produktkategorie: Waschtischarmatur
Typ: Zeit-/Sensorarmatur
Modell: PROTRONIC-S Mischer
Registrierungsnummer: WA10540-20130228



Wasser Effizienz Kriterien

Durchfluss > 6,0 l/min ≤ 9,0 l/min	*	
Durchfluss geregelt ≥ 4,0 l/min ≤ 6,0 l/min	**	▶
Durchflussunabhängige Temperatureinstellung	*	
Temperaturbegrenzung / Kaltwasserventil	**	▶
Selbstschlussarmatur	*	
Sensorarmatur	**	▶

Informationen Betrieb und Montage: www.well-online.eu.

A Label of EUnited Valves

European Valve Manufacturers Association

WELL Public

Water Efficiency Label

Manufacturer: Franke Aquarotter GmbH
Product category: Wash basin valve
Type: Time/sensor valve
Model: PROTRONIC-S Mischer
Registration number: WA10540-20130228



Water Efficiency Criteria

Flow rate > 6,0 l/min ≤ 9,0 l/min	*
Controlled flow rate ≥ 4,0 l/min ≤ 6,0 l/min	**
Flow-independent temperature setting	*
Temperature limit / Cold water valve	**
Self-closing valve	*
Sensor valve	**

Information about use and installation: www.well-online.eu.

A Label of EUnited Valves

European Valve Manufacturers Association

ALG

SARL BFIX
Résidence Chaabani
Val d'Hydra part N°06-C Hydra 08
DZ-16035 HYDRA-ALGER / Algeria
t: +213 (0)21 60 13 60
e: customer@bfixgroupe.com

AUS

PR Kitchen and Washroom Systems Pty Ltd
83 Bangholme Road
Dandenong South VIC 3175
t: +61 (0)3 9700 9100
e: info@prks.com.au

AUT

Franke GmbH
Oberer Achdamm 52
6971 Hard / Austria
t: +43 (0)5574 6735 0
e: ws-info.at@franke.com

BEL

Franke N.V.
Ring 10
9400 Ninove / Belgium
t: +32 (0)54 310130
e: ws-info.be@franke.com

CAN

Franke Kindred Canada Limited
1000 Franke Kindred Road
Midland, Ontario L4R 4K9 / Canada
t: +1 855 446 5663
e: ws-info.ca@franke.com

CZE

Franke Aquarotter GmbH
Parkstrasse 1 - 5
14974 Ludwigsfelde / Germany
t: +420 281 090 429
e: ws-info.cz@franke.com

EGY

Franke Kitchen Systems Egypt S.A.E.
1st Industrial Zone
6th October City, Cairo / Egypt
t: +202 3828 0000
e: ws-info.eg@franke.com

FIN / SWE / NOR / DEN / EST

Franke Finland Oy
Vartiokujja 1
76850 Naarajaervi / Finland
t: +358 (0)15 3411 1
e: ws-info.fi@franke.com

FRA

Franke GmbH
Oberer Achdamm 52
6971 Hard / Autriche
t: 0800 909 216
e: ws-info.fr@franke.com

GBR / IRL

Franke Sissons Ltd.
Carrwood Road
Chesterfield S41 9QB / United Kingdom
t: +44 (0)1246 450 255
e: ws-info.uk@franke.com

GBR

Dart Valley Systems Ltd.
Kemings Close, Long Road,
Paignton TQ4 7TW / United Kingdom
t: +44 (0)1803 529 021
e: sales@dartvalley.co.uk

GER

Franke Aquarotter GmbH
Parkstrasse 1 - 5
14974 Ludwigsfelde / Germany
t: +49 (0)3378 818 0
e: ws-info.de@franke.com

GEO

Franke Caucasus Ltd.
7, Agladze Street
Tbilisi, 0154 / Georgia
t: +995 (0)32 2351672
e: info@franke-ge.com

ITA

Franke GmbH
Oberer Achdamm 52
6971 Hard / Austria
t: 800 789233
e: ws-info.it@franke.com

NED

Franke N.V.
Ring 10
9400 Ninove / Belgium
t: +31 (0)492 72 82 24
e: ws-info.nl@franke.com

POL

Franke Aquarotter GmbH
Parkstrasse 1-5
14974 Ludwigsfelde / Germany
t: +48 (0) 22 711 61 17
e: ws-info.pl@franke.com

POR

Franke Portugal S.A.
Estrada de Talaide, Edifício 3, Cruzamento
de Sao Marcos, 2735-531 Cacém / Portugal
t: +351 (0)21 426 9670
e: ws-info.pt@franke.com

RSA

Franke Kitchen Systems (Pty) Ltd.
1194 South Coast Road
4060 Moberni / South Africa ZAF
t: +27 (0)31 450 6300
e: ws-info.za@franke.com

RUS

Franke Neva GmbH
Volgogradsky prospect, 43 building 3
109316 Moscow / Russia
t: +7 495 225 56 58
e: fs-info.ru@franke.com

SLO

Barjans d.o.o.
Pod Hruševco 20
1360 Vrhnika / Slovenia
t: +386 (0)1 750 66 40
e: info@barjans.si

SUI

Franke Washroom Systems AG
Franke-Strasse 9, Postfach 237
4663 Aarburg / Switzerland
t: +41 (0)62 787 3131
e: ws-info.ch@franke.com

SVK

INGEMA s.r.o.
Močarianska 1
071 01 Michalovce / Slovakia
t: +421 (0)56 640 36 12
e: ingema@ingema.sk

TUN

HANDASSA GROUP
48 Av. Taieb Mhiri Imm. Les Jasmins apt. n°5.
2080 Ariana / Tunisia
t: +216 (0)71 702 272
e: info@handassagroup.com.tn

TUR

Franke Mutfak ve Banyo Sistemleri San. ve
Tic. A.S
Gebze Organize Sanayi Bölgesi
Tembelova Alanı 3500 sokak No: 3503
Gebze, Kocaeli / Türkiye
t: +90 (0)262 644 6595
e: ws-info.tr@franke.com

UAE

Franke L.L.C
P.O. Box 14511
Ras Al Khaimah / United Arab Emirates
t: +971 (0)7 2034 700
e: ws-info.ae@franke.com

USA

Franke Kindred Canada Limited
1000 Franke Kindred Road
Midland, Ontario L4R 4K9 / Canada
t: +1 855 526 0503
e: commercial-info.us@franke.com

**Other East-European Countries
(HU/RO/BG/CRO/SRB/BIH/UKR)**

Franke Aquarotter GmbH
Parkstrasse 1 - 5
14974 Ludwigsfelde / Germany
t: +49 (0)3378 818 0
e: ws-info.de@franke.com

Other Countries:

Franke GmbH
Oberer Achdamm 52
6971 Hard / Austria
t: +43 (0)5574 6735 0
e: ws-info.int@franke.com